

COMPACT AND BACKLASH FREE.

single-position
multi-position
load holding
full disengagement

TORQUE LIMITERS

SERIES SK + ES | 0.1 – 2,800 Nm



R+W[®]
COUPLING TECHNOLOGY

THE ULTIMATE COUPLING FROM 0.1 – 2,800 Nm

www.rw-america.com

optional
stainless steel

single-position
multi-position
load holding
full disengagement

BACKLASH-FREE TORQUE LIMITERS

Areas of application:

- Machine tools
- CNC machining centers
- Woodworking machines
- Automation equipment
- Textile machinery
- Industrial robots
- Sheet metal processing machines
- Printing + Converting machinery
- Servo + DC motor drives

Features:

- Precise overload protection
- Absolutely backlash-free and torsionally rigid (R+W patented principle)
- Compact, simple design
- Disengagement detection is achieved through indexing ring movement
- Low residual friction following disengagement
- Low moment of inertia
- Disengagement within msec

MODELS

FEATURES

POSSIBLE APPLICATIONS

SK 1



With conical clamp or clamping hub

- Integral bearings for timing belt pulley or sprocket
- Compact, simple design
- Adjustable settings

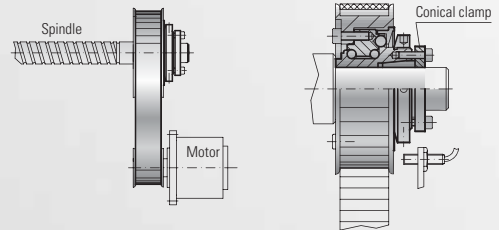

see pages 6-7

SKN



With clamping hub for indirect drives

- Integral bearing for timing belt pulley or sprocket
- Compact, simple design
- Adjustable settings
- Frictional clamping hub
- Simple assembly

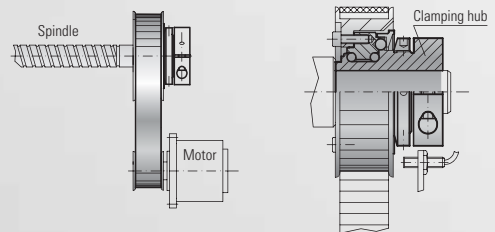

see pages 8-9

SKP



With keyway connection for indirect drives

- Integral bearings for timing belt pulley or sprocket
- Compact, simple design
- Adjustable settings

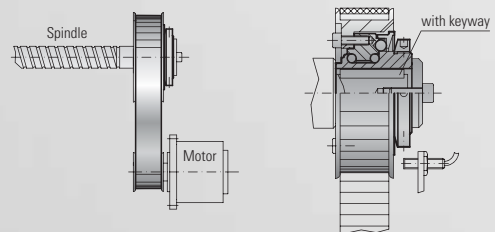

see pages 10-11

SK 2



With clamping hub for direct drives

- Easy assembly
- Low moment of inertia
- Compact
- Compensates for shaft misalignment
- Adjustable settings

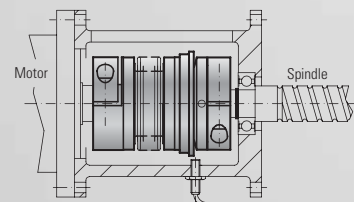

see page 12

single-position
multi-position
load holding
full disengagement

MODELS

FEATURES

POSSIBLE APPLICATIONS

SK 3



With conical clamp connection for direct drives

- High clamping forces
- High degree of operational dependability
- Compensates for shaft misalignment
- Adjustable settings

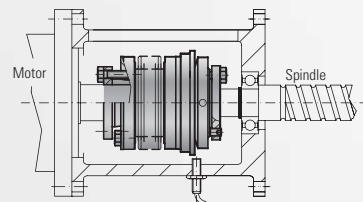

see page 13

SK 5



With clamping hub, press-fit version for direct drives

- Easy mounting and dismounting
- Electrically and thermally insulated
- Compensates for shaft misalignment
- Adjustable settings

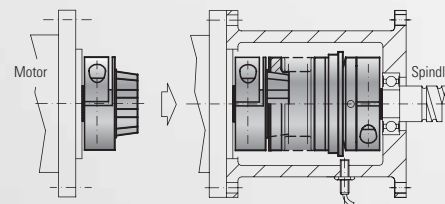

see pages 14-15

ES 2



With clamping hub for direct drives

- Easy assembly
- Damps vibrations
- Compensates for shaft misalignment
- Adjustable settings

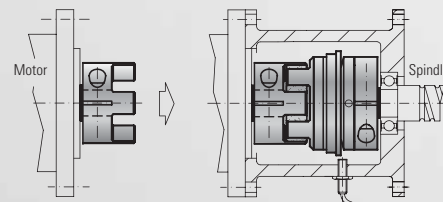

see pages 16-17

ESL



Torque limiter „Economy Class“

- Cost effective
- Compact
- Multi-position

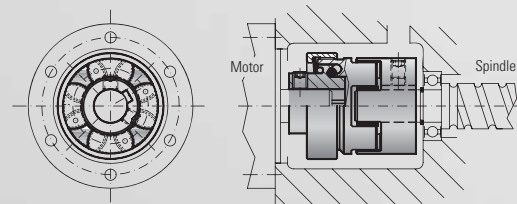

see page 18

EEx



For use in explosive environments

- EEx available for the entire product range
- for the hazardous areas 1/21 and 2/22 the SERVOMAX EEx Elastomer couplings are registered according to the directive ATEX 95a



see page 19

single-position
multi-position
load holding
full disengagement

OVERVIEW

PATENTED BACKLASH-FREE TORQUE LIMITERS FROM R+W

Single-position re-engagement

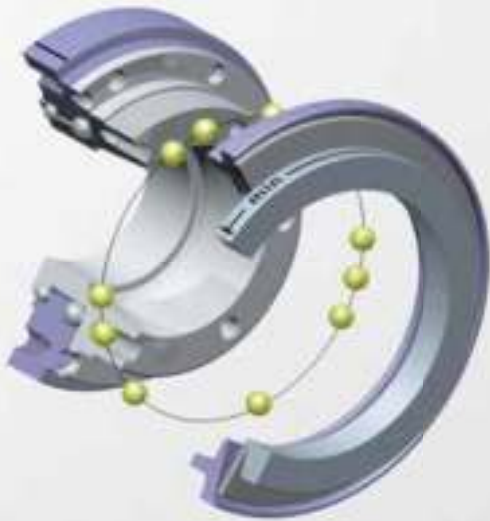

Standard version

- After the overload has been removed, the coupling will re-engage precisely 360° from the original disengagement position.
- Signal at overload
- Suitable for use in machine tools, packaging machinery, automation systems and other applications requiring precise timing.

! Every model in this catalog is available in all 4 versions.

R+W TORQUE

Load holding Version

- Mechanical overload detection device
- In the event of a torque overload, the drive and driven elements are not fully separated and are only allowed limited rotation.
- Guaranteed to hold the load and signal an overload.
- Automatic engagement after the torque level has dropped.
- Signal at overload to detect with mechanical switch or proximity sensor.
- Suitable for use on presses, load lifting equipment or on any applications where the drive and driven elements cannot be disengaged.

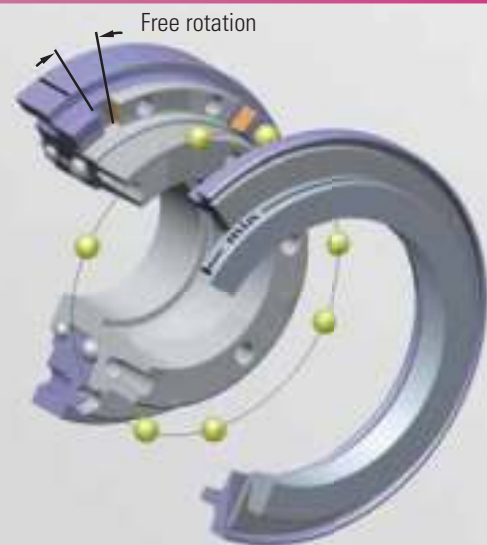

POSSIBLE FUNCTION SYSTEMS

Multi-position re-engagement

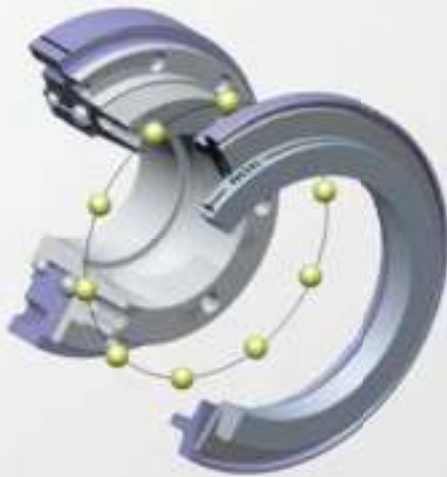

- Coupling re-engages at multiple set angular intervals.
- Immediate availability of the machine as soon as the overload has been removed.
- Signal at overload with mechanical switch or proximity sensor
- Standard engagement every 60°
- Re-engagement after 30, 45, 90 or 120 degrees available upon request

LIMITERS

Full disengagement

- Note:**
Coupling can be disengaged manually.
Please contact R+W.
- Permanent separation of drive and driven elements in the event of a torque overload.
 - Signal at overload with mechanical switch or proximity sensor
 - No residual friction
 - Rotating elements slow down freely
 - Coupling can be re-engaged manually (Engagement every 60°); other engagement intervals optional
 - For use in high speed applications





single-position
multi-position
load holding
full disengagement



Pulley not included.

MODEL SK1

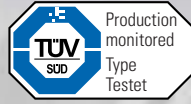

BACKLASH FREE TORQUE LIMITER

with conical clamp connection

Miniature Design Series 1.5 - 10

Standard clamping hub

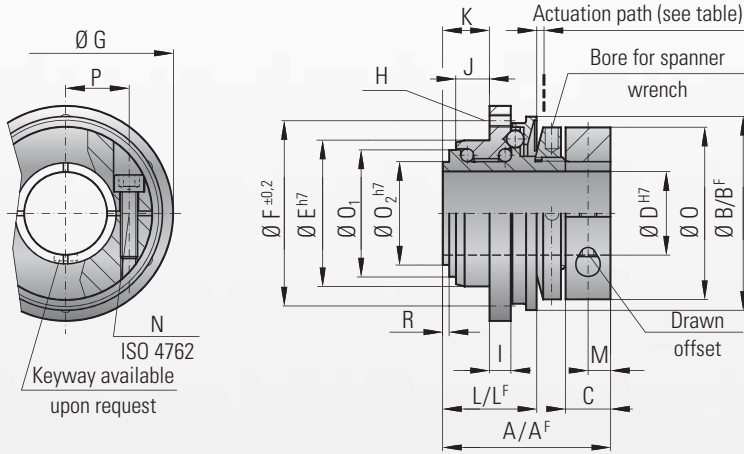

Material:

High strength, hardened steel

Design:

Model SK1 from 1.5 - 10 Nm with clamping hub
Model SK1 von 15 - 2,800 Nm with conical clamp
Absolutely backlash free through the frictional clamping connection

Temperature range:

-30 to +120° C

Service life:

Maintenance free when operated within the technical specifications

Fit tolerance:

Tolerance between hub and shaft 0.01 - 0.05 mm

Optional sealed version for food-grade applications (see page 26)

Design Series 15-2500

Standard conical clamp

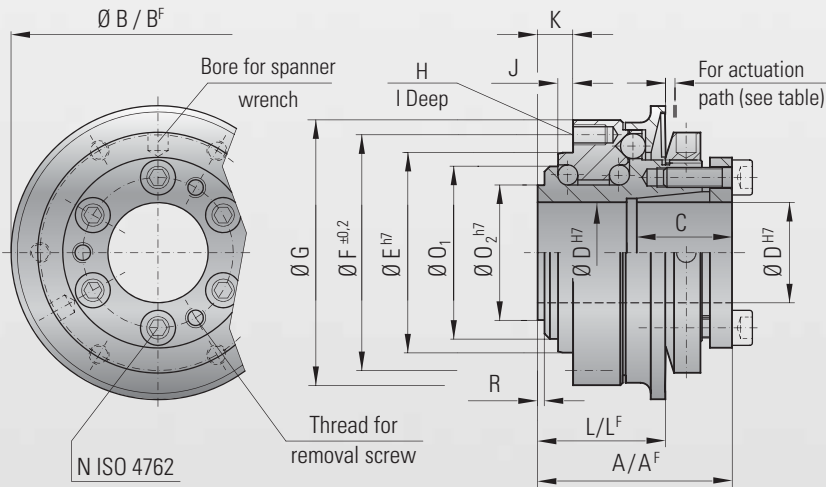

Optional ATEX

Certified under the ATEX 95a directive for the hazardous zones 1/21 and 2/22



Ordering specifications

SK1 / 10 / W / 14 / 4 / 2-6 / xx

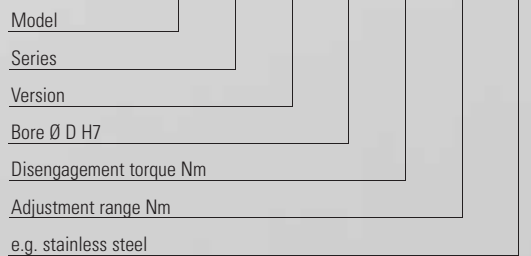

All data is subject to change without notice.

Possible versions

- W = Single-position engagement
- D = Multi-position engagement
- G = Load holding
- F = Full disengagement

For the maximum permissible radial load capacity for all SK 1 models, see installation instructions on page 22/23

optional
stainless steel

single-position
multi-position
load holding
full disengagement

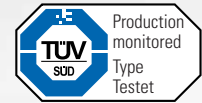

MODEL SK 1		Miniature Design													
		Series													
		1.5	2	4.5	10	15	30	60	150	200	300	500	800	1500	2500
Adjustment range available from - to (approx. values) (Nm)	T _{KN}	0.1-0.6 0.4-1 0.8-2	0.2-1.5 0.5-2.2 1.5-3.5	1-3 2-4.5 3-7	2-6 4-12 7-18	5-15 12-25 20-40 35-70	5-20 10-30 20-60 50-100	10-30 25-80 50-115	20-70 45-150 80-225	30-90 60-160 140-280 250-400	100-200 150-240 220-440	80-200 200-350 320-650	400-650 500-800 650-950	600-800 700-1200 1000-1800	1500-2000 2000-2500 2300-2800
Adjustment range available from - to (approx. values) ("F" Version) (Nm)	T _{KN}	0.3-0.8 or 0.6-1.3	0.5-2	2.5-4.5	2-5 4-10 8-15	7-15	8-20 or 16-30	10-30 20-40 30-60	20-60 40-80 80-150	80-140 or 130-200	120-180 160-300 300-450	50-150 100-300 250-500	200-400 or 450-850	1000-1250 or 1250-1500	1400-2200 or 1800-2700
Overall length (mm)	A	23	28	32	39	40	50	54	58	63	70	84	95	109	146
Overall length ("F" Version) (mm)	A ^F	23	28	32	39	40	50	54	58	66	73	88	95	117	152
Actuation ring Ø (mm)	B	23	29	35	45	55	65	73	92	99	120	135	152	174	242
Actuation ring Ø, ("F" Version) (mm)	B ^F	24	32	42	51.5	62	70	83	98	117	132	155	177	187	258
Clamping fit length (mm)	C	7	8	11	11	19	22	27.5	32	32	41	41	49	61	80
Inner diameter from Ø to Ø H7 (mm)	D	4-8	4-12	5-14	6-20	8-22	12-22	12-29	15-37	20-44	25-56	25-56	30-60	35-70	50-100
Pilot diameter h7 (mm)	E	14	22	25	34	40	47	55	68	75	82	90	100	125	168
Bolt-hole circle diameter ± 0,2 (mm)	F	22	28	35	43	47	54	63	78	85	98	110	120	148	202
Flange outside diameter -0,2 (mm)	G	26	32	40	50	53	63	72	87	98	112	128	140	165	240
Thread	H	4x M2	4x M2.5	6x M2.5	6x M3	6x M4	6x M5	6x M5	6x M6	6x M6	6x M8	6x M8	6x M10	6x M12	6x M16
Thread depth (mm)	I	3	4	4	5	6	8	9	10	10	10	12	15	16	24
Centering length -0,2 (mm)	J	2.5	3.5	5	8	3	5	5	5	5	6	9	10	13.5	20
Distance (mm)	K	5	6	8	11	8	11	11	12	12	15	21	19	25	34
Distance (mm)	L	11	15	17	22	27	35	37	39	44	47	59	67	82	112
Distance ("F" Version) (mm)	L ^F	11.5	16	18	24	27	37	39	41.5	47	51.5	62	75	94	120
Distance (mm)	M	3.5	4	5	5										
Screw ISO 4762	N	1x M 2.5	1x M 3	1x M 4	1x M 4	6x M4	6x M5	6x M5	6x M6	6x M6	6x M8	6x M8	6x M10	6x M12	6x M16
Tightening torque (Nm)		1	2	4	4.5	4	6	8	12	14	18	25	40	70	120
Outside diameter clamp ring Ø (mm)	O	20	25	32	40										
Diameter (mm)	O ₁	13	18	21	30	35	42	49	62	67	75	84	91	112	154
Diameter h7 (mm)	O ₂	11	14	17	24	27	32	39	50	55	65	72	75	92	128
Distance between centers (mm)	P	6.5	8	10	15										
Distance (mm)	R	1	1.3	1.5	1.5	2.5	2.5	2.5	2.5	3	3	4	4	4.5	6
Moment of inertia (10 ⁻³ kgm ²)	J _{ges}	0.01	0.02	0.05	0.07	0.15	0.25	0.50	1.60	2.70	5.20	8.60	20	31.5	210
Approx. weight (kg)		0.03	0.065	0.12	0.22	0.4	0.7	1.0	1.3	2.0	3.0	4.0	5.5	10	28
Actuation path (mm)		0.7	0.8	0.8	1.2	1.5	1.5	1.7	1.9	2.2	2.2	2.2	2.2	3.0	3.0

A^F, B^F, L^F = Full disengagement version



single-position
multi-position
load holding
full disengagement



Pulley not included.

MODEL SKN

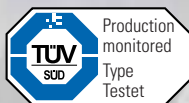

BACKLASH FREE TORQUE LIMITER

with clamping hub

Series 15 - 1500 Nm

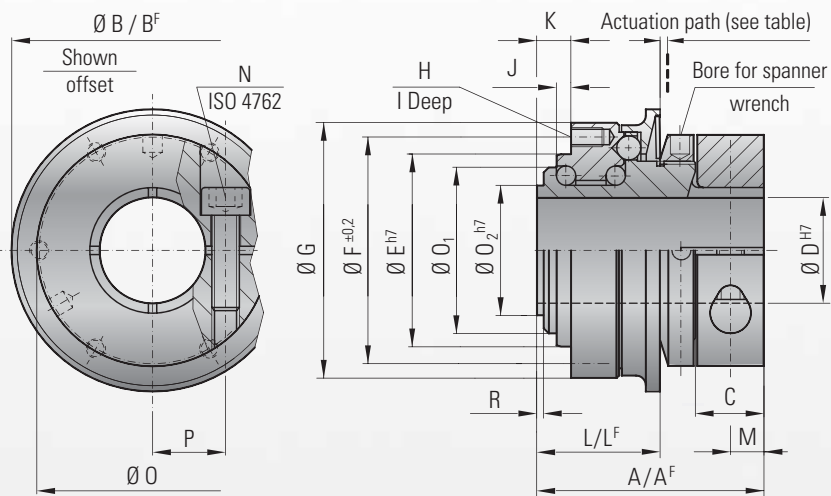

Material:

Torque limiting portion: high-strength, hardened steel
Clamping hub: up to series 500, aluminium;
from series 800, steel

Design:

With clamping hub and 1 radial screw ISO 4762
Absolutely backlash free through frictional
clamping connection

Temperature range:

-30 to +120° C

Service life:

Maintenance free when operated within the
technical specifications

Fit tolerance:

Tolerance between hub and shaft 0.01 - 0.05 mm

**Optional sealed version for food-grade
applications (see page 26)**

Easy mounting and dismounting

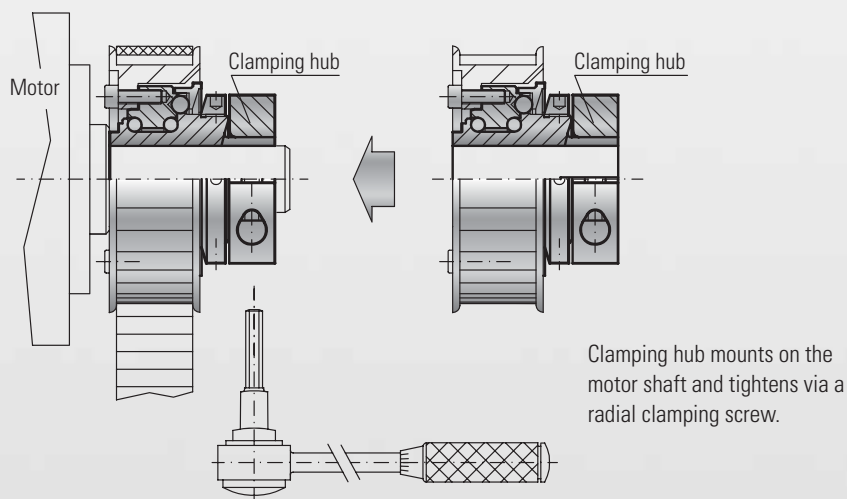

Option ATEX

**Certified under the ATEX 95a directive for
the hazardous zones 1/21 and 2/22**



Ordering specifications

SKN / 60 / W / 20 / 60/25-80 / xx

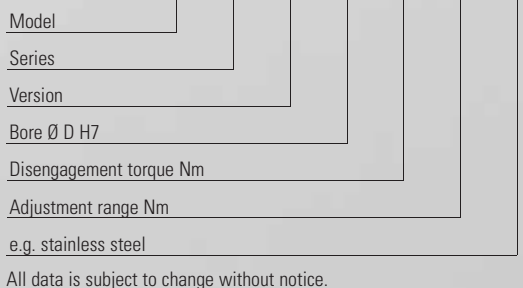

Possible versions

- W = Single-position engagement
- D = Multi-position engagement
- G = Load holding
- F = Full disengagement

**For the maximum permissible radial
load capacity for all SKN models,
see installation instructions on page 22/23.**

optional
stainless steel

single-position
multi-position
load holding
full disengagement

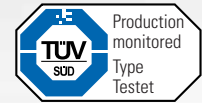

MODEL SKN											
			15	30	60	150	200	300	500	800	1500
Adjustment range available from - to (approx. values) (Nm)	T _{KN}		5-10 or 8-20	10-25 or 20-40	10-30 or 25-80	20-70 45-150 80-180	30-90 60-160 120-240	100-200 150-240 200-320	80-200 200-350 300-500	400-650 500-800 600-850	600-800 700-1200 1000-1800
Adjustment range available from - to (approx. values) ("F" Version) (Nm)	T _{KN}		7-15	8-20 or 16-30	10-30 20-40 30-60	20-60 40-80 80-150	80-140 or 130-200	120-180 or 160-300	50-150 100-300 250-500	200-400 or 450-800	1000-1250 or 1250-1500
Overall length (mm)	A		47	59	65	71	80	84	101	115	145
Overall length ("F" Version) (mm)	A ^F		47	59	65	73	83	87	107	126	154
Actuation ring Ø (mm)	B		55	65	73	92	99	120	135	152	174
Actuation ring Ø ("F" Version) (mm)	B ^F		62	70	83	98	117	132	155	177	187
Clamping fit length (mm)	C		13.5	16	20	23	26	26	30	35	46
Inner diameter from Ø to Ø H7 (mm)	D		12-22	14-25.4	16-32	19-40	24-44	30-56	35-60	40-62	50-72
Inner Diameter from Ø to Ø H7 with keyway (mm)	D		8-19	12-25.4	12-30	15-38	20-44	25-50	25-58	30-60	35-72
Pilot diameter h7 (mm)	E		40	47	55	68	75	82	90	100	125
Bolt-hole circle diameter ± 0,2 (mm)	F		47	54	63	78	85	98	110	120	148
Flange outside diameter -0,2 (mm)	G		53	63	72	87	98	112	128	140	165
Thread	H		6xM4	6xM5	6xM5	6xM6	6xM6	6xM8	6xM8	6xM10	6xM12
Thread depth (mm)	I		6	8	9	10	10	10	12	15	16
Centering length -0,2 (mm)	J		3	5	5	5	5	6	9	10	13.5
Distance (mm)	K		8	11	11	12	12	15	21	19	25
Distance (mm)	L		27	35	37	39	44	47	59	67	82
Distance ("F" Version) (mm)	L ^F		27	37	39	41.5	47	51.5	62	75	94
Distance (mm)	M		6.5	7.5	9.5	11	13	13	14.5	18	22.5
Screw ISO 4762	N		M5	M6	M8	M10	M12	M12	M14	M16	M20
Tightening torque (Nm)	N		8	15	40	70	120	130	210	270	500
Clamp ring Ø (mm)	O		49	55	67	85	94	110	121	134	157
Diameter (mm)	O ₁		35	42	49	62	67	75	84	91	112
Diameter h7 (mm)	O ₂		27	36	39	50	55	65	72	75	92
Distance between centers (mm)	P		17.5	19	23.5	30	32.5	39	43.5	45	52
Distance (mm)	R		2.5	2.5	2.5	2.5	3	3	4	4	4.5
Moment of inertia (10 ⁻³ kgm ²)	J _{ges}		0.15	0.25	0.50	1.60	2.70	5.20	8.60	20	31.5
Approx. weight (kg)			0.4	0.7	1.0	1.3	2.0	3.0	4.0	5.5	10
Actuation path (mm)			1.5	1.5	1.7	1.9	2.2	2.2	2.2	2.2	3.0

A^F, B^F, L^F = Full disengagement version



single-position
multi-position
load holding
full disengagement



Pulley not included.

MODEL SKP

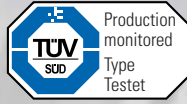

BACKLASH FREE TORQUE LIMITER

With pure keyway connection

Miniature series 1.5 - 10

With pure keyway connection

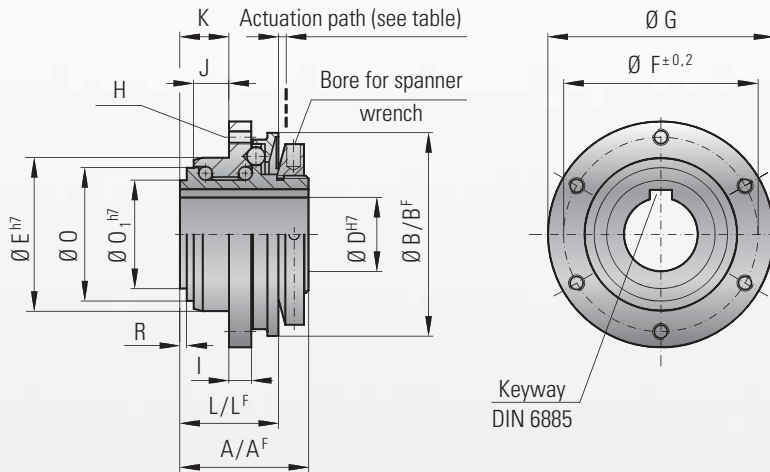

Material:

High-strength, hardened steel

Design:

Pure keyway connection
Torque limiting element is backlash free

Temperature range:

-30 to +120° C

Service life:

Maintenance free when operated within the technical specifications

Fit tolerance:

Tolerance between hub and shaft 0.01 – 0.05 mm

Optional sealed version for food-grade applications (see page 26)

Series 15-2500

With pure keyway connection

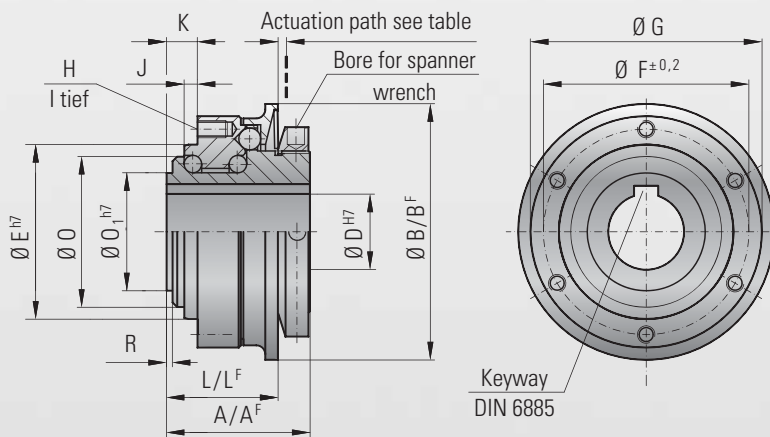

Option ATEX

Certified under the ATEX 95a directive for the hazardous zones 1/21 and 2/22



Ordering specifications

SKP/10 / W / 14 / 4 / 2-6 / xx

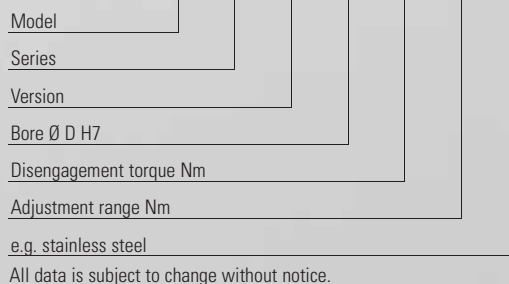

Possible versions

- W = Single-position engagement (standard)
- D = Multi-position engagement
- G = Load holding
- F = Full disengagement

For the maximum permissible radial load capacity for all SKP models, see installation instructions on page 22/23

optional
stainless steel

single-position
multi-position
load holding
full disengagement

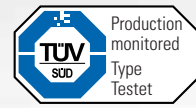

MODEL SKP	Miniature Design														
	Series														
		1.5	2	4.5	10	15	30	60	150	200	300	500	800	1500	2500
Adjustment range available from - to (approx. values) (Nm)	T_{KN}	0.1-0.6 0.4-1 0.8-2	0.2-1.5 0.5-2.2 1.5-3.5	1-3 2-4.5 3-7	2-6 4-12 7-18	5-15 12-25 20-40 35-70	5-20 10-30 20-60 50-100	10-30 25-80 45-150 80-225	20-70 45-150 80-225	30-90 60-160 140-280 250-400	100-200 150-240 220-440	80-200 200-350 320-650	400-650 500-800 650-950	600-800 700-1200 1000-1800	1500-2000 2000-2500 2300-2800
Adjustment range available from - to (approx. values) ("F" Version) (Nm)	T_{KN}	0.3-0.8 or 0.6-1.3	0.5-2	2.5-4.5	2-5 4-10 8-15	7-15	8-20 or 16-30	10-30 20-40 30-60	20-60 40-80 80-150	80-140 or 130-200	120-180 160-300 300-450	50-150 100-300 250-500	200-400 or 450-850	1000-1250 or 1250-1500	1400-2200 or 1800-2700
Overall length A (mm)	A	15.5	20	22	28	34	43	46	48.5	54	57	71.5	80	93	135
Overall length A ("F" Version) (mm)	A ^F	15.5	20	22	28	34	43	46	48.5	57	60	75	91	110	141
Actuation ring Ø (mm)	B	23	29	35	45	55	65	73	92	99	120	135	152	174	242
Actuation ring Ø, ("F" Version) (mm)	B ^F	24	32	42	51.5	62	70	83	98	117	132	155	177	187	258
Bore Diameter from Ø to Ø H7 (mm)	D	4-8	4-10	5-12	6-16	8-19	12-25.4	12-30*	15-38	20-44	25-50	25-58	30-60	35-73	50-95
Pilot diameter h7 (mm)	E	14	22	25	34	40	47	55	68	75	82	90	100	125	168
Bolt-hole circle diameter ± 0,2 (mm)	F	22	28	35	43	47	54	63	78	85	98	110	120	148	202
Flange outside diameter -0,2 (mm)	G	26	32	40	50	53	63	72	87	98	112	128	140	165	240
Thread	H	4xM2	4xM2.5	6xM2.5	6xM3	6xM4	6xM5	6xM5	6xM6	6xM6	6xM8	6xM8	6xM10	6xM12	6xM16
Thread depth (mm)	I	3	4	4	5	6	8	9	10	10	10	12	15	16	24
Centering length -0,2 (mm)	J	2.5	3.5	5	8	3	5	5	5	5	6	9	10	13.5	20
Distance (mm)	K	5	6	8	11	8	11	11	12	12	15	21	19	25	34
Distance (mm)	L	11	15	17	22	27	35	37	39	44	47	59	67	82	112
Distance ("F" Version) (mm)	L ^F	11.5	16	18	24	27	37	39	41.5	47	51.5	62	75	94	120
Diameter (mm)	O	13	18	21	30	35	42	49	62	67	75	84	91	112	154
Diameter h7 (mm)	O ₁	11	14	17	24	27	32	39	50	55	65	72	75	92	128
Distance (mm)	R	1	1.3	1.5	1.5	2.5	2.5	2.5	2.5	3	3	4	4	4.5	6
Moment of inertia (10 ⁻³ kgm ²)	J _{ges}	0.01	0.02	0.05	0.07	0.15	0.25	0.50	1.60	2.70	5.20	8.60	20	31.5	210
Approx. weight (kg)		0.03	0.065	0.12	0.22	0.4	0.7	1.0	1.3	2.0	3.0	4.0	5.5	10	28
Actuation path (mm)		0.7	0.8	0.8	1.2	1.5	1.5	1.7	1.9	2.2	2.2	2.2	2.2	3.0	3.0

A^F, B^F, L^F = Full disengagement version *Ø 30 with flat keyway, keyway depth (t₂) 2.8 + 0.2

Keyway according to the DIN 6885 Standard

D ₁	from to	6 8	8 10	10 12	12 17	17 22	22 30	30 38	38 44	44 50	50 58	58 65	65 75	75 85	85 95	95 110
b ^{JS9}		2	3	4	5	6	8	10	12	14	16	18	20	22	25	28
h		2	3	4	5	6	7	8	8	9	10	11	12	14	14	16
t ₁		1.2	1.8	2.5	3	3.5	4	5	5	5.5	6	7	7.5	9	9	10
t ₂	+0.1 / +0.2	1	1.4	1.8	2.3	2.8	3.3	3.3	3.3	3.8	4.3	4.4	4.9	5.4	5.4	6.4

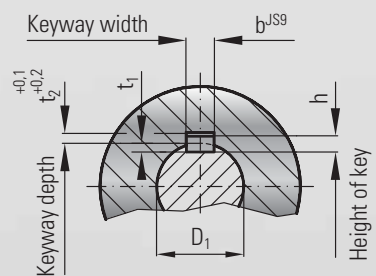

Imperial dimension keyways also available.



single-position
multi-position
load holding
full disengagement



MODEL SK2

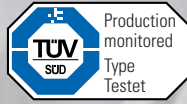

BACKLASH FREE TORQUE LIMITER

with clamping hub

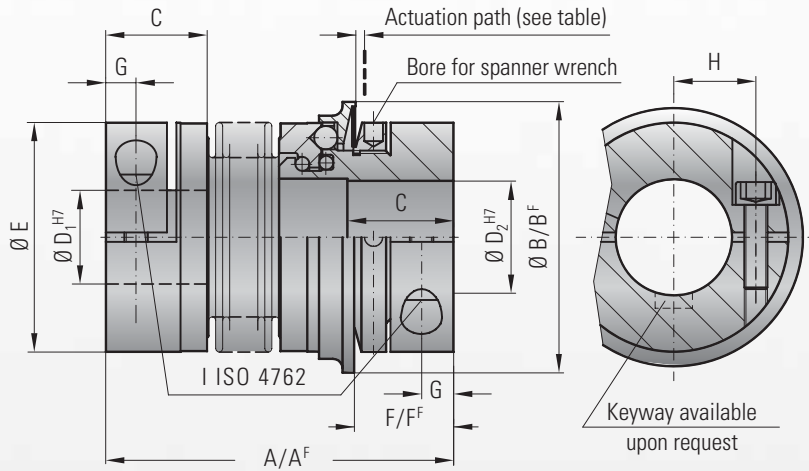

Material:

Bellows made of highly elastic stainless steel
Torque limiter section: High strength hardened steel

Hub material: up to series 80 aluminium from series up 150 steel

Design:

With clamping hub and 1 radial screw ISO 4762
Absolutely backlash free through frictional clamping connection

Temperature range:

-30° C to +100° C

Service life:

Maintenance free when operated within the technical specifications

Fit tolerance:

Tolerance between hub and shaft 0.01 – 0.05 mm

Ordering specifications: see page 15

Optional sealed version for food-grade applications (see page 26)

Optional ATEX Certification (see page 19)

Model SK 2		Series													
		1.5	2	4.5	10	15	30	60	80	150	200	300	500	800	1500
Adjustment range available from - to (approx. values) (Nm)	T _{KN}	0.1-0.6 0.4-1 0.8-1.5	0.2-1.5 or 0.5-2	1-3 or 3-6	2-6 or 4-12	5-10 or 8-20	10-25 or 20-40	10-30 or 25-80	20-70 or 30-90	20-70 45-150 80-180	30-90 60-160 120-240	100-200 150-240 200-320	80-200 200-350 300-500	400-650 500-800 650-850	650-800 700-1200 1000-1800
Adjustment range available from - to (approx. values) ("F" Version) (Nm)	T _{KN}	0.3-0.8 or 0.6-1.3	0.5-2	2.5-4.5	2-5 or 5-10	7-15	8-20 or 16-30	20-40 or 30-60	20-60 or 40-80	20-60 40-80 80-150	80-140 or 130-200	120-180 or 160-300	60-150 100-300 250-500	200-400 or 450-800	1000-1250 or 1250-1500
Overall length (mm)	A	42	46 51	57 65	65 74	75 82	87 95	102 112	115 127	116 128	128 140	139 153	163 177	190	223
Overall length, ("F" Version) (mm)	A ^F	42	46 51	57 65	65 74	75 82	87 95	102 112	117 129	118 130	131 143	142 156	167 181	201	232
Actuation ring Ø (mm)	B	23	29	35	45	55	65	73	92	92	99	120	135	152	174
Actuation ring Ø (ful disengagement) (mm)	B ^F	24	32	42	51.5	62	70	83	98	98	117	132	155	177	187
Fit length (mm)	C	11	13	16	16	22	27	31	35	35	40	42	51	48	67
Inner diameter from Ø to Ø H7 (mm)	D ₁ /D ₂	3-8	4-12	5-14	6-20	10-26	12-30	15-32	19-42	19-42	24-45	30-60	35-60	40-75	50-80
Outer diameter of coupling (mm)	E	19	25	32	40	49	55	66	81	81	90	110	123	134	157
Distance (mm)	F	12	13	15	17	19	24	28	31	31	35	35	45	50	63
Distance ("F" Version) (mm)	F ^F	11.5	12	14	16	19	22	29	31	30	33	35	43	54	61
Distance (mm)	G	3.5	4	5	5	6.5	7.5	9.5	11	11	12.5	13	17	18	22.5
Distance between centers (mm)	H	6	8	10	15	17	19	23	27	27	31	39	41	2x48	2x55
ISO 4762 screws	I	M2.5	M3	M4	M4	M5	M6	M8	M10	M10	M12	M12	M16	2xM16	2xM20
Tightening torque (Nm)	I	1	2	4	4.5	8	15	40	50	70	120	130	200	250	470
Approx. weight (kg)		0.035	0.07	0.2	0.3	0.4	0.6	1.0	2.0	2.4	4.0	5.9	9.6	14	21
Moment of inertia (10 ⁻³ kgm ²)	J _{RES}	0.01	0.01 0.01	0.02 0.02	0.06 0.07	0.10 0.15	0.27 0.32	0.75 0.80	1.80 1.90	2.50 2.80	5.10 5.30	11.5 11.8	22.8 23.0	42.0	83.0
Torsional stiffness (10 ³ Nm/rad)	C _T	0.7	1.2 1.3	7 5	9 8	20 15	39 28	76 55	129 85	175 110	191 140	420 350	510 500	780	1304
Lateral ± (mm)	max. values	0.15	0.15 0.20	0.20 0.25	0.20 0.30	0.15 0.20	0.20 0.25	0.20 0.25	0.20 0.25	0.20 0.25	0.20 0.25	0.25 0.30	0.25 0.30	0.30 0.35	0.35 0.35
Angular ± (degrees)	max. values	1	1 1.5	1.5 2	1.5 2	1 1.5	1 1.5	1 1.5	1 1.5	1 1.5	1 1.5	1.5 2	1.5 2	2 2.5	2.5 2.5
Lateral spring stiffness (N/mm)		70	40 30	290 45	280 145	475 137	900 270	1200 420	920 255	1550 435	2040 610	3750 1050	2500 840	2000	3600
Actuation path (mm)		0.7	0.8	0.8	1.2	1.5	1.5	1.7	1.9	1.9	2.2	2.2	2.2	2.2	3

A^F, B^F, F^F = Full disengagement version

(larger sizes on request)

optional
ATEX certification

single-position
multi-position
load holding
full disengagement



MODEL SK3



BACKLASH FREE TORQUE LIMITER

with tapered conical connection

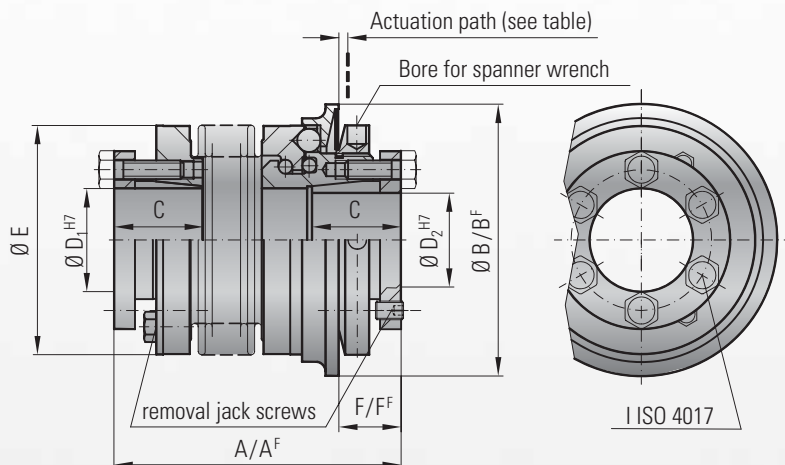

Material:

Bellows made of highly elastic stainless steel
Torque limiter section: High strength hardened steel
Hub material: Steel

Design:

With tapered conical clamp and removal jack screws.

Absolutely backlash free through frictional clamping connection

Temperature range:

-30 to +100° C

Service life:

Maintenance free when operated within the technical specifications

Fit tolerance:

Tolerance between hub and shaft 0.01 – 0.05 mm

Ordering specifications: see page 15

Optional sealed version for food-grade applications (see page 26)

Optional ATEX Certification (see page 19)

Model SK 3	Series																					
	15		30		60		150		200		300		500		800		1500		2500			
Adjustment range available from (approx. values) (Nm)	T_{KN}		5-10 or 8-20		10-25 or 20-40		10-30 or 25-80		20-70 or 45-150 or 80-200		30-90 or 60-160 or 80-280		100-200 or 150-240 or 220-400		80-200 or 200-350 or 300-500		400-650 or 500-800 or 600-900		650-850 or 700-1200 or 1000-1800		1500-2000 or 2000-2500 or 2300-2800	
Adjustment range available from (approx. values) ("F" Version) (Nm)	T_{KN}		7-15		8-20 or 16-30		20-40 or 30-60		20-60 or 40-80 or 80-150		80-140 or 130-200		120-180 or 160-300		60-150 or 100-300 or 250-500		200-400 or 450-800		1000-1250 or 1250-1500		1400-2200 or 1800-2700	
Overall length (mm)	A		62	69	72	80	84	94	93	105	99	111	114	128	123	136	151	175	246			
Overall length ("F" Version) (mm)	A^F		62	69	72	80	84	94	93	105	102	114	117	131	127	140	151	184	252			
Actuation ring \varnothing (mm)	B		55		65		73		92		99		120		135		152		174		243	
Actuation ring \varnothing ("F" Version) (mm)	B^F		62		70		83		98		117		132		155		177		187		258	
Fit length (mm)	C		19		22		27		32		32		41		41		49		61		80	
Inner diameter from \varnothing to $\varnothing H7$ (mm)	D_1/D_2		10-22		12-23		12-29		15-37		20-44		25-56		25-60		30-60		35-70		50-100	
Outer diameter of coupling (mm)	E		49		55		66		81		90		110		123		133		157		200	
Distance (mm)	F		13		16		18		19		19		23		25		31		30		34	
Distance ("F" Version) (mm)	F^F		13		14		17		18		17		20		22		20		26		31	
6x ISO 4017	I		M4		M5		M5		M6		M6		M8		M8		M10		M12		M16	
Tightening torque (Nm)	I		4		6		8		12		14		18		25		40		70		120	
Approx. weight (kg)	I		0.3		0.4		1.2		2.3		3.0		5.0		6.5		9.0		16.3		35	
Moment of inertia (10^{-3} kgm ²)	J_{RES}		0.10	0.15	0.28	0.30	0.75	0.80	1.90	2.00	2.80	3.00	5.50	6.00	11.0	12.8	20	42	257			
Torsional stiffness (10^3 Nm/rad)	C_T		20	15	39	28	76	55	175	110	191	140	420	350	510	500	780	1304	3400			
Lateral \pm (mm)	max. values		0.15	0.20	0.20	0.25	0.20	0.25	0.20	0.25	0.25	0.30	0.25	0.30	0.30	0.35	0.35	0.35	0.35	0.35	0.35	
Angular \pm (degrees)	max. values		1	1.5	1	1.5	1	1.5	1	1.5	1.5	2	1.5	2	2	2.5	2.5	2.5	2.5	2.5	2.5	
Lateral spring stiffness (N/mm)	max. values		475	137	900	270	1200	380	1550	435	2040	610	3750	1050	2500	840	2000	3600	6070			
Actuation path (mm)	max. values		1.5		1.5		1.7		1.9		2.2		2.2		2.2		2.2		3		3	

A^F, B^F, F^F = Full disengagement version

www.rw-america.com

(larger sizes upon request)



single-position
multi-position
load holding
full disengagement

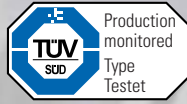

MODEL SK5



BACKLASH FREE TORQUE LIMITER

blind-mate version, with clamping hub

Material:

Bellows: stainless steel
Torque limiting portion: high-strength, hardened steel
Hub material: series 80 and below: aluminum;
series 150 and up: steel

Design:

With clamping hub and 1 radial screw ISO 4762
Absolutely backlash free through frictional clamping connection

Temperature range:

-30 to +100° C

Service life:

Maintenance free when operated within the technical specifications

Fit tolerance:

Tolerance between hub and shaft 0.01 – 0.05 mm

Ordering specifications:

see page 15

Optional sealed version for food-grade applications (see page 26)

Optional ATEX Certification (see page 19)

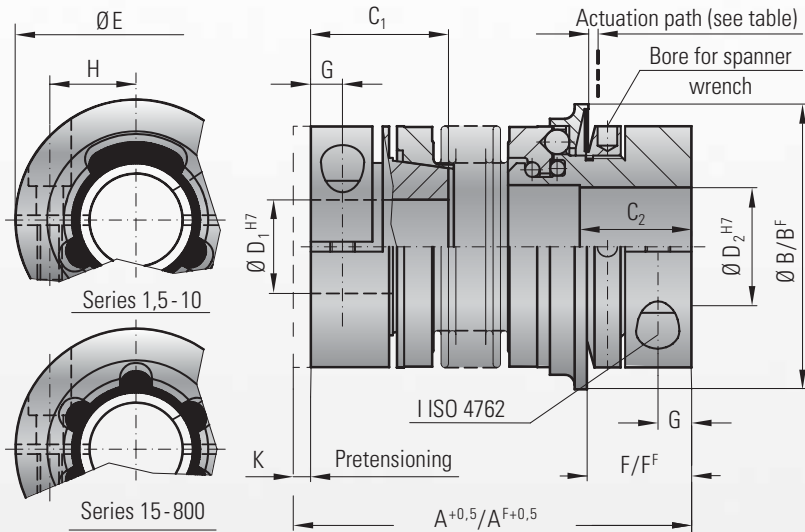

MODEL SK 5	Series																									
	1.5	2	4.5	10	15	30	60	80	150	300	500	800														
Adjustment range available from - to (approx. values) (Nm)	0.1-0.6 0.4-1 0.8-1.5		0.2-1.5 or 0.5-2		1-3 or 3-6		2-6 or 4-12		5-10 or 8-20		10-25 or 20-40		20-70 or 30-90		20-70 or 45-150		100-200 150-240 200-320		80-200 200-350 300-500		400-650 500-800 650-850					
Adjustment range available from - to (approx. values) ("F" Version) (Nm)	0.3-0.8 or 0.6-1.3		0.5-2		2.5-4.5		2-5 or 5-10		7-15		8-20 or 16-30		20-40 or 30-60		20-60 or 40-80		80-150		120-200 or 160-300		60-150 100-300 250-500		200-400 or 450-800			
Overall length +0,5 inserted (mm)	A		44	48	54	60	68	70	79	76	83	89	97	105	115	115	127	116	128	143	157	166	180	196		
Overall length +0,5 inserted ("F" Version) (mm)	AF		44	48	54	60	68	70	79	76	83	89	97	105	115	117	129	118	130	146	160	170	184	207		
Actuator ring Ø (mm)	B		23	29	35	45	55	65	73	73	92	92	92	92	92	92	92	92	120	135	135	152	152			
Actuator ring Ø ("F" Version) (mm)	BF		24	32	42	51.5	62	70	83	83	98	98	98	98	98	98	98	98	132	155	155	177	177			
Clamping fit length C1/C2 (mm)	C1/C2		14	11	16	13	19	16	21	16	28	22	33	27	39	31	43	35	43	35	52	42	61	52	74	48
Bore Diameter from Ø to Ø H7 (mm)	D1		3-8	4-12	5-16	5-20	5-20	8-22	8-22	10-25	12-32	14-38	14-38	14-38	14-38	14-38	14-42	14-42	14-42	30-56	35-60	35-60	40-62	40-62		
Bore Diameter from Ø to Ø H7 (mm)	D2		3-8	4-12	5-14	5-20	5-20	8-26	8-26	10-30	12-32	14-42	14-42	14-42	14-42	14-42	14-42	14-42	14-42	30-60	35-60	35-60	40-75	40-75		
Outer diameter (mm)	E		19	25	32	40	40	49	49	55	66	81	81	81	81	81	81	81	81	110	123	123	134	134		
Distance (mm)	F		12	13	15	17	17	19	19	24	28	31	31	31	31	31	31	31	31	35	45	45	50	50		
Distance ("F" Version) (mm)	FF		11.5	12	14	16	16	19	19	22	22	29	29	29	29	29	29	29	29	36	43	43	54	54		
Distance (mm)	G		3.5	4	5	5	5	6.5	6.5	7.5	9.5	11	11	11	11	11	11	11	11	13	17	17	18	18		
Distance between centers (mm)	H		6	8	10	15	15	17	17	19	23	27	27	27	27	27	27	27	27	39	41	41	2x48	2x48		
ISO 4762 screws	I		M2.5	M3	M4	M4	M4	M5	M5	M6	M8	M10	M10	M10	M10	M10	M10	M10	M10	M12	M16	M16	2xM16	2xM16		
Tightening torque (Nm)	I		1	2	4	4.5	4.5	8	8	15	40	50	50	50	50	50	50	50	50	130	200	200	250	250		
Pretensioning, approx. (mm)	K		0.1-0.5	0.2-0.7	0.2-0.7	0.2-1.0	0.2-1.0	0.2-1.0	0.2-1.0	0.2-1.0	0.5-1.0	0.5-1.0	0.5-1.0	0.5-1.0	0.5-1.0	0.5-1.0	0.5-1.0	0.5-1.0	0.5-1.0	0.5-1.5	0.5-2.0	0.5-2.0	0.5-2.0	0.5-2.0		
Axial recovery of coupling max. (N)	K		4	8	5	15	10	25	30	20	12	50	30	70	45	48	32	82	52	157	106	140	96	200		
Approx. weight (kg)	K		0.038	0.07	0.2	0.3	0.3	0.4	0.4	0.6	1.4	2	2	2	2	2	2	2	2	5.9	9.6	9.6	15	15		
Moment of inertia (10 ⁻³ kgm ²)	Jges		0.01	0.01	0.01	0.02	0.02	0.06	0.07	0.10	0.15	0.27	0.32	0.75	0.80	1.80	1.90	2.50	2.80	6.50	7.00	13.0	17.0	50		
Torsional stiffness (10 ³ Nm/rad)	CT		0.7	1.2	1.3	7	5	8	7	12	10	18	16	40	31	68	45	90	60	220	190	260	250	390		
Lateral ± (mm)	max. values		0.15	0.15	0.20	0.20	0.25	0.20	0.30	0.15	0.20	0.20	0.25	0.20	0.25	0.20	0.25	0.20	0.25	0.25	0.30	0.30	0.35	0.35		
Angular ± (degrees)	max. values		1	1	1.5	1.5	2	1.5	2	1	1.5	1	1.5	1	1.5	1	1.5	1	1.5	1.5	2	2	2.5	2.5		
Lateral spring stiffness (N/mm)	max. values		70	40	30	290	45	280	145	475	137	900	270	1200	420	920	290	1550	435	3750	1050	2500	840	2000		
Actuation path (mm)	max. values		0.7	0.8	0.8	1.2	1.2	1.5	1.5	1.5	1.5	1.7	1.7	1.7	1.7	1.7	1.7	1.7	1.7	2.2	2.2	2.2	2.2	2.2		

AF, BF, FF = Full disengagement version

optional
stainless steel

single-position
multi-position
load holding
full disengagement

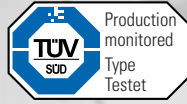

blind-mate version, with clamping hub

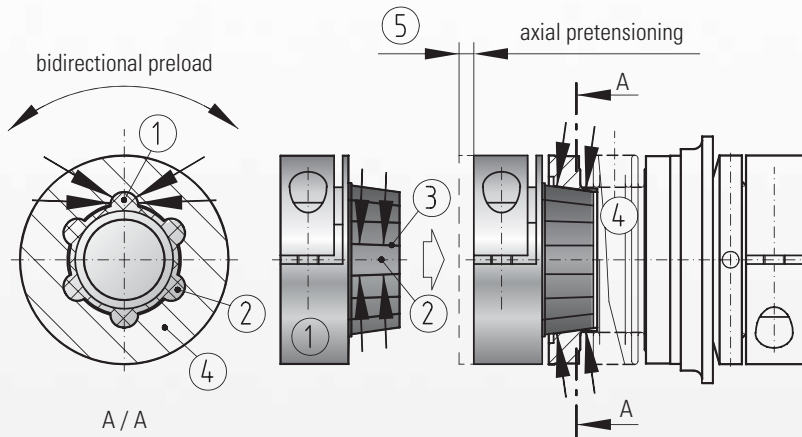

Design details

Six self-centering, tapered drive projections (2) have been formed into the taper segment, which has been molded onto an aluminium hub (1).

The six projections are configured conically in a longitudinal direction (3).

The mating-piece consists of a metal bellows with a tapered female element (4).

Absolutely backlash-free torque transmission is ensured due to the axial pretensioning (5) of the metal bellows during mounting. This slight pretensioning has no negative influence on the operation of the metal bellows or on the shaft bearing.

Possible applications for backlash-free, press-fit torque limiter SK 5

1 Applications with limited accessibility. The dismantling of a single-piece coupling is too labor intensive.

2 The **press fit design** allows the motor or gearbox unit to be removed by simply pulling it out when servicing is required.

Dismounting the coupling is possible **without loosening** the hub fastening screws. Therefore, clamping screw access holes are not required.

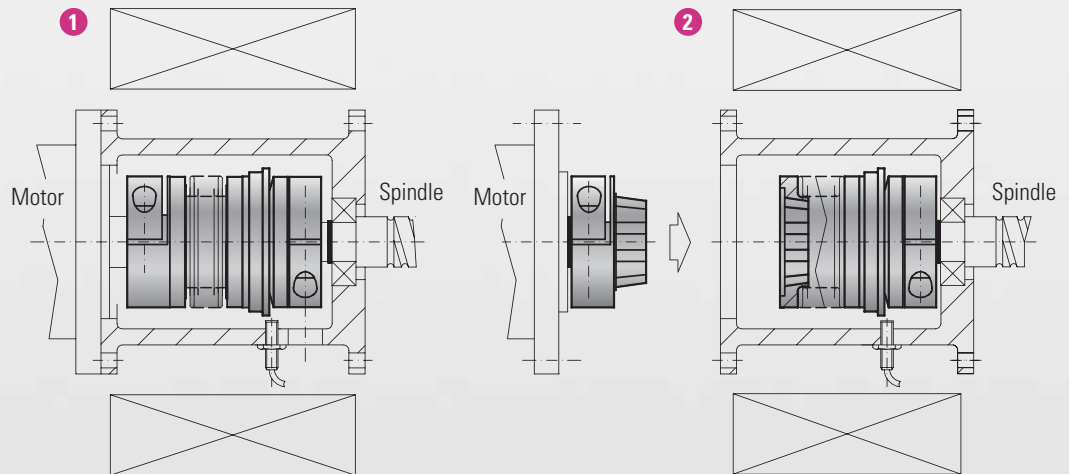

Ordering specifications

Required information for models SK 2, SK 3 and SK 5

Model	SK2 / 60 / 102 / D / 16 / 19 / 25/10-30/XX
Series	
Overall length mm	
Version	
Bore Ø D1 H7	
Bore Ø D2 H7	
Disengagement torque Nm	
Adjustment range Nm	
e.g. stainless steel	

All data is subject to change without notice.

Possible versions

- W = Single-position engagement (standard)
- D = Multi-position engagement
- G = Load holding
- F = Full disengagement



single-position
multi-position
load holding
full disengagement



MODEL ES2

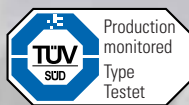

BACKLASH FREE TORQUE LIMITER

with clamping hubs

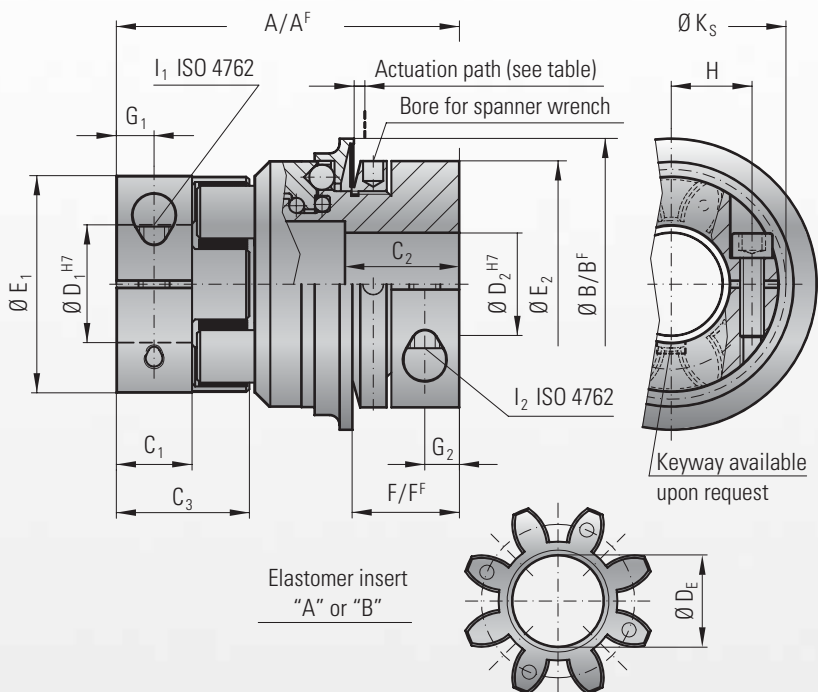

Material:

Torque limiting portion: high-strength, hardened steel with rust protection (oxidized)
Clamping hub D₁: up to series 450: high-strength aluminum; series 800 and up: steel
Clamping hub D₂: up to series 60: high-strength aluminum; series 150 and up: steel
Elastomer insert: precision molded, wear-resistant, thermally stable polymer

Design:

Two coupling hubs concentrically machined with concave driving jaws
One side with an integrated torque limiter
Available in single-position, multi-position, load holding, and full disengagement versions.

Temperature range:

See table below

Fit tolerance:

Tolerance between hub and shaft 0.01 – 0.05 mm

Optional sealed version for food-grade applications (see page 26)

Optional ATEX Certification (see page 19)

Possible versions

- W = Single-position re-engagement (standard)
- D = Multi-position re-engagement
- G = Load holding
- F = Full disengagement

Ordering specifications

ES2 / 10 / A / W / 14 / 12 / 8 / 4-12 / XX

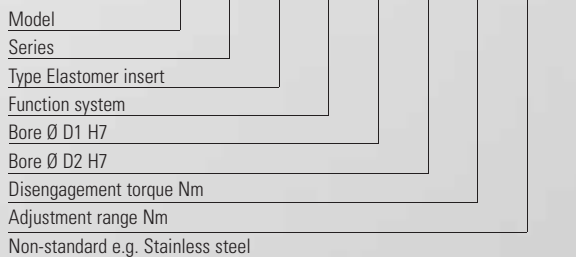

All data is subject to change without notice.

Specification of the Elastomer inserts

Type	Shore hardness	Color	Material	Relative damping (ψ)	Temperature range	Features
A	98 Sh A	red	TPU	0.4 - 0.5	-30°C to +100°C	high damping
B	64 Sh D	green	TPU	0.3 - 0.45	-30°C to +120°C	high torsional stiffness
D	65 Sh D	black	TPU	0.3 - 0.45	-10°C to + 70°C	electrically conductive

The values of the relative damping were determined at 10 Hz and +20°C.

Model ES	Series																	
	5		10		20		60		150		300		450		800		1500	
Elastomer type	A	B	A	B	A	B	A	B	A	B	A	B	A	B	A	B	A	B
Static torsional stiffness (Nm/rad) C_T	150	350	260	600	1140	2500	3290	9750	4970	10600	12400	18000	15100	27000	41300	66080	87600	109000
Dynamic torsional stiffness (Nm/rad) C_{Tdyn}	300	700	541	1650	2540	4440	7940	11900	13400	29300	23700	40400	55400	81200	82600	180150	175000	216000
lateral $\left[\begin{array}{c} \text{---} \\ \text{---} \\ \text{---} \end{array} \right]$ (mm)	0.08	0.06	0.1	0.08	0.1	0.08	0.12	0.1	0.15	0.12	0.18	0.14	0.2	0.18	0.25	0.2	0.5	0.3
angular $\left[\begin{array}{c} \text{---} \\ \text{---} \\ \text{---} \end{array} \right]$ (degré)	1	0.8	1	0.8	1	0.8	1	0.8	1	0.8	1	0.8	1	0.8	1	0.8	1.5	1
axial $\left[\begin{array}{c} \text{---} \\ \text{---} \\ \text{---} \end{array} \right]$ (mm)	±1		±1		±2		±2		±2		±2		±2		±2		±3	

Static torsional stiffness calculated at 50% T_{KN}

Dynamic torsional stiffness calculated at T_{KN}



single-position
multi-position
load holding
full disengagement

MODEL ES2

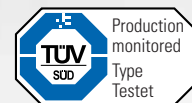

BACKLASH FREE TORQUE LIMITER

MODEL ES 2		Series																	
		5		10		20		60		150		300		450		800		1500	
Type (Elastomer insert)		A	B	A	B	A	B	A	B	A	B	A	B	A	B	A	B	A	B
Rated torque (Nm)	T_{KN}	9	12	12.5	16	17	21	60	75	160	200	325	405	530	660	950	1100	1950	2450
Max. torque* (Nm)	T_{Kmax}	18	24	25	32	34	42	120	150	320	400	650	810	1060	1350	1900	2150	3900	4900
Adjustment range possible from -to (Nm)	T_{KN}	1-3 or 3-6		2-6 or 4-12		10-25 or 20-40		10-30 or 25-80		20-70 45-150 80-180		100-200 150-240 200-320		80-200 200-350 300-500		400-650 500-800 600-900		600-850 700-1200 1000-1800	
Adjustment range ("F" Version) possible from -to (Nm)	T_{KN}^F	2.5-4.5		2-5 or 5-10		8-20 or 16-30		20-40 or 30-60		20-60 40-80 80-150		120-180 or 180-300		60-150 100-300 250-500		200-400 or 450-800		1000-1250 or 1250-1500	
Overall length (mm)	A	50		60		86		96		106		140		164		179		245	
Overall length ("F" Version) (mm)	A _F	50		60		86		96		108		143		168		190		257	
Outer diameter of actuation ring (mm)	B	35		45		65		73		92		120		135		152		174	
Outer diameter of actuation ring ("F" Version) (mm)	B _F	42		51.5		70		83		98		132		155		177		187	
Clamping fit length (mm)	C ₁	8		10.3		17		20		21		31		34		46		88	
Fit length (mm)	C ₂	14		16		27		31		35		42		51		45		86	
Length of hub (mm)	C ₃	16.7		20.7		31		36		39		52		57		74		120	
Inner diameter from Ø to Ø H7 (mm)	D ₁	4-12.7		5-16		8-25		12-32		19-36		20-45		28-60		35-80		35-90	
Inner diameter from Ø to Ø H7 (mm)	D ₂	6-14		6-20		12-30		15-32		19-42		30-60		35-60		40-75		50-80	
Inner diameter (Elastomer insert) (mm)	D _E	10.2		14.2		19.2		26.2		29.2		36.2		46.2		60.5		79	
Diameter of the hub (mm)	E ₁	25		32		42		56		66.5		82		102		136.5		160	
Diameter of the hub (mm)	E ₂	19		40		55		66		81		110		123		132		157	
Distance (mm)	F	15		17		24		28		31		35		45		50		63	
Distance ("F" Version) (mm)	F _F	14		16		22		29		30		35		43		54		61	
Distance (mm)	G ₁	4		5		8.5		10		11		15		17.5		23		36	
Distance (mm)	G ₂	5		5		7.5		9.5		11		13		17		18		22.5	
Distance between centers (mm)	H ₁	8		10.5		15		21		24		29		38		50.5		2x 57	
Screws (ISO 4762)	I ₁	M3		M4		M5		M6		M8		M10		M12		M16		2x M16	
Tightening torque (Nm)	I ₁	2		4.5		8		15		35		70		120		290		300	
Distance between centers SK-side (mm)	H ₂	10		15		19		23		27		39		41		48		2x 55	
Screws (ISO 4762)	I ₂	M4		M4		M6		M8		M10		M12		M16		2x M16		2x M20	
Tightening torque (Nm)	I ₂	4		4.5		15		40		70		130		200		250		470	
Diameter with screwhead (mm)	K _S	25		32		44.5		57		68		85		105		139		155	
Approx. weight (kg)		0.2		0.3		0.6		1.0		2.4		5.8		9.3		14.3		26	
Moment of inertia (10 ⁻³ kgm ²)	J _{ges}	0.02		0.06		0.25		0.7		2.3		11		22		33.5		185	
Actuation path (mm)		0.8		1.2		1.5		1.7		1.9		2.2		2.2		2.2		3.0	

Information about static and dynamic torsional stiffness as well as max. possible misalignment see page 16

A^F, B^F, F^F = Full disengagement version

Maximum transmittable torque (Nm) of clamping hub based on bore diameter (mm)

Series	Ø 4	Ø 5	Ø 8	Ø 16	Ø 19	Ø 25	Ø 30	Ø 32	Ø 35	Ø 45	Ø 50	Ø 55	Ø 60	Ø 65	Ø 70	Ø 75	Ø 80	
5	1,5	2	8															
10		4	12	32														
20			20	35	45	60												
60				50	80	100	110	120										
150					120	160	180	200	220									
300					200	230	300	350	380	420								
450							420	480	510	600	660	750	850					
800									700	750	800	835	865	900	925	950	1000	
1500										1900	2600	2900	3200	3500	3800	4000	4300	4600

Higher torque values possible through additional keyway



ratcheting



MODEL ESL

LOW BACKLASH TORQUE LIMITERS

with keyway connection

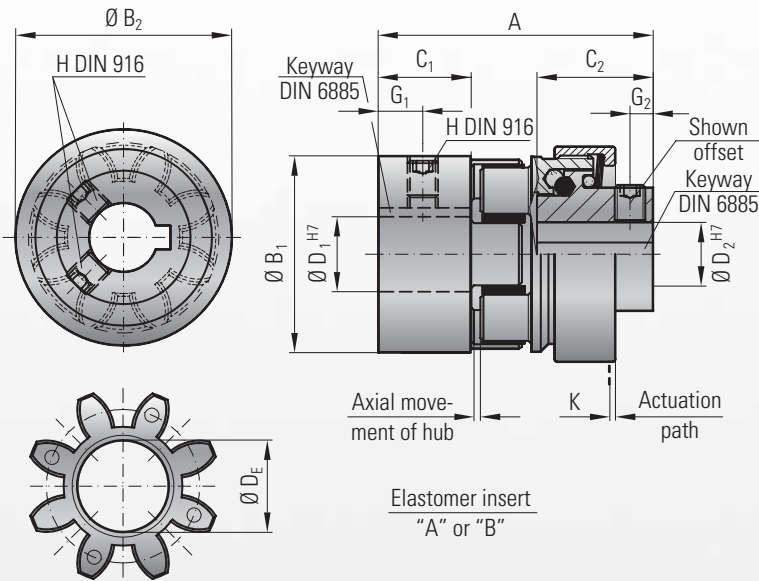

Material:

Torque limiting portion: high-strength steel
Clutching balls: hardened steel
Clamping hubs: high-strength aluminum
Elastomer insert: precision molded, wear-resistant, thermally stable polymer

Design:

Zero backlash elastomer coupling with integral torque limiter. All sizes available in standard multi-position design.

Speed:

Negligible abrasion with disengagement speeds up to 200 rpm
Higher speeds available upon request

Fit tolerance:

Tolerance between hub and shaft 0.01 – 0.05 mm

MODEL ESL		Series									
		5		10		20		60		150	
Type (Elastomer insert)		A	B	A	B	A	B	A	B	A	B
Rated torque (Nm)	T_{Kn}	9	12	12.5	16	17	21	60	75	160	200
Adjustment range* from - to (Nm)	T_{Kn}	1-6		1-12		3-19		5-60		20-150	
Overall length (mm)	A	34		45		64		80		90	
Diameter of the hub (mm)	B_1	25		32		42		56		66.5	
Diameter of the hub (mm)	B_2	29		32		46		59		75	
Clamping fit length (mm)	C_1	12.5		12		25		30		35	
Clamping fit length (mm)	C_2	11.5		20		22		31		35	
Inner diameter from Ø to Ø H7 (mm)	D_1	6-15		6-18		8-25		12-32		19-38	
Inner diameter from Ø to Ø H7 (mm)	D_2	6-10		6-12		8-19		12-24		19-32	
Inner diameter max. (elastomer) (mm)	D_E	10.5		14.2		19.2		26.2		29.2	
Distance (mm)	G_1	5		6		9		11		12	
Distance (mm)	G_2	2.5		3.5		4		4		4	
Screws DIN 916**	H	depending on bore diameter see below table									
Approx. weight (kg)		0.05		0.15		0.2		0.5		1	
Moment of inertia (10^{-3} kgm^2)	J_1 / J_2	0.01		0.02		0.08		0.15		0.5	
Actuation path (mm)	K	0.6		0.6		0.7		1.1		1.4	

* Adjustment range preset by R+W. Information about static and dynamic torsional stiffness as well as max. possible misalignment see page 16

Ordering specifications

ESL / 10 / A / 14 / 12 / 10 / XX

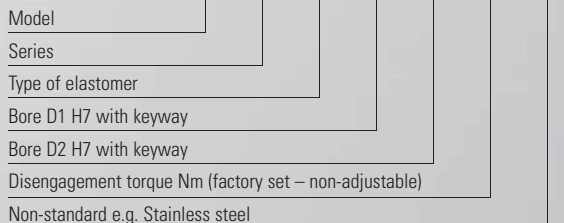

All data is subject to change without notice.

Installation instruction

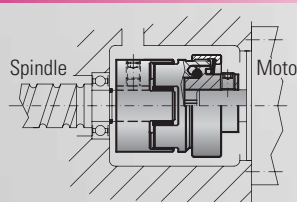

Disengagement torque setting

The ESL torque limiter is factory preset at the required disengagement torque and is not adjustable.

**** Set screw**

D_1 / D_2	H
- Ø 10	M3
Ø 11-12	M4
Ø 13-30	M5
Ø 31-58	M8
Ø 59-80	M10

Bore sizes < Ø 6 are manufactured without a keyway

optional
stainless steel

MODEL ATEX

FOR USE IN HAZARDOUS AREAS AND EXPLOSIVE ATMOSPHERE

ATEX 95 is regulated by the new European directive. Generally the explosive atmosphere is classified in 3 different zones.

Zone 0:

A place in which an explosive atmosphere consists out of a mixture of air and flammable substances in the form of gas, vapor or mist, and **is present frequently, continuously** or for **extended periods**.

Zone 20:

Is relevant for an explosive atmosphere in the form of clouds of combustible dust in air under the same conditions as above.

Zone 1:

Described as a place in which an explosive atmosphere consists of a mixture of air and flammable substances in the form of gas, vapor or mist, and is **likely to occur** in normal operation occasionally.

Zone 21:

Is relevant for an explosive atmosphere in the form of clouds of combustible dust in air under the same conditions as above.

Zone 2:

A place in which an explosive atmosphere consists of a mixture of air with flammable substances in the form of gas, vapor or mist, and is **not likely to occur** in normal operation but, if it does occur, it will persist **for a short period only**.

Zone 22:

Relevant for an explosive atmosphere in the form of a cloud of combustible dust in air under the same conditions as above.

For the classified zones 1/21 and 2/22 the Servomax couplings EK-EEX do have an accreditation according to ATEX 95/a



Atmosphere Explosive

Design of ATEX torque limiter:

Full disengagement version offered for ATEX environments to avoid excess friction subsequent to disengagement.

All dimensions and material are the same as the standard products.

An IP65 rated sealed intermediate flange must be used with all bellows-style torque limiters.

The ES2 style torque limiter comes with an electrically conductive insert (Sh65D). The insert prevent electrostatic charging and sparking.

Rating:

For safety purposes, all misalignment, speed and torque ratings are reduced by 30%. Technical data available upon request.

Maintenance:

Visually inspect the torque limiter at regular maintenance intervals.

Assembly instructions:

Assembly and maintenance instructions will be provided with each torque limiter.

Mechanical ATEX Limit switch

Order-No.: 658.1624.004

Technical drawing

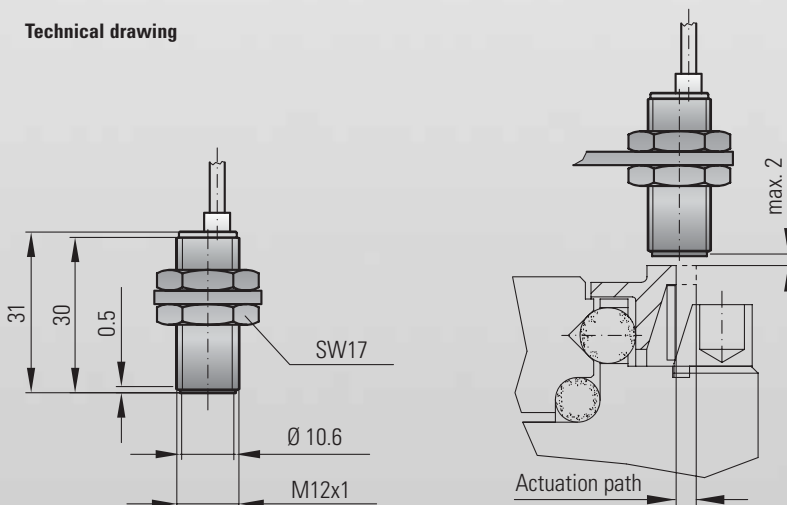

Note:
After installation, it is necessary to fully test the functionality of the limit switch.

Technical Data

Voltage	DC 5 ... 25V
Output current	> 3mA
Switch frequency	≤ 800 Hz
Temperature range	-25 °C to +70 °C
Protective system	IP 67
Switch type	open
Detection gap	max. 2 mm
Certification	TÜV 98 ATEX 1293
Identification	(Ex) II 2 G EEx ib IIC T6

Switch diagram

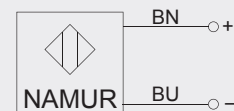

single-position
multi-position
load holding
full disengagement

ACCESSORIES

BACKLASH FREE TORQUE LIMITER

Spanner wrench for torque adjustment (for DIN 1816 nuts)

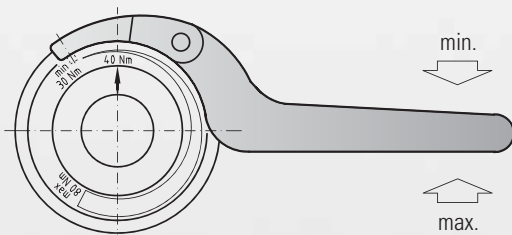

Miniature torque limiters (series 1.5 – 10) do not require a spanner wrench. These adjustment nuts can be turned with a bolt or a drift pin.

Order-No.: see table

Series ES2	Series SK	• Single-position • Multi-position • Load holding	Full disengagement
x	15	No. 49/4	No. 49/4
20	30	No. 55/4	No. 55/4
60	60	No. 66/5	No. 66/5
150	80/150	No. 82/5	No. 82/5
x	200	No. 90/6	No. 98/5
300	300	No. 114/6	No. 114/6
450	500	No. 126/8	No. 126/8
800	800	No. 134/8	No. 144/8
x	1500	No. 163/8	No. 163/8
x	2500	No. 210/10	No. 226/10

Mechanical Limit Switch (appropriate from series 30 up)

Technical drawing

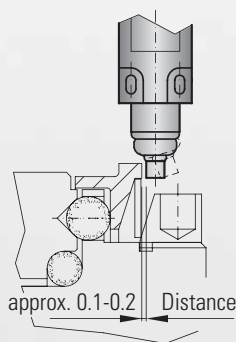
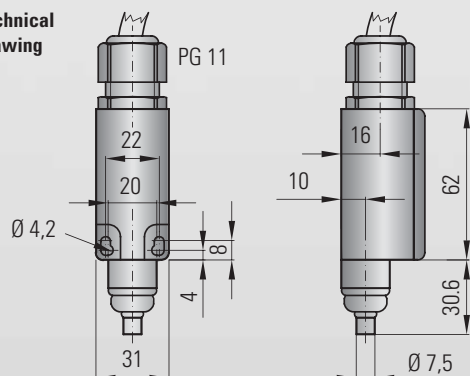

Note:

After installation, it is necessary to fully test the functionality of the limit switch.

The plunger should be placed as close as possible to the actuation ring of the torque limiter (approx. 0.1 – 0.2 mm)

Order-No.: 618.6740.644

Technical data

Max. voltage	500 V AC
Max. constant current	10 A
Protective System	IP 65
Contact system	Opener (forced separating)
Temperature range	- 30 - +80 °C
Actuation	Plunger (metal)

Switch diagram

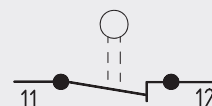

The mechanical limit switch is suitable for series 30 and up. For smaller torque limiters, the proximity sensor is recommended.

Proximity sensor

Technical drawing

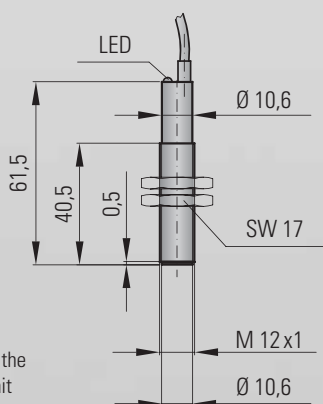

Note:

After installation, it is necessary to fully test the functionality of the limit switch.

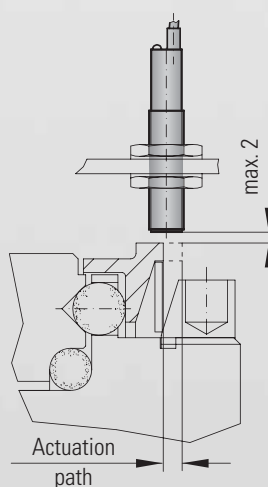

Order-No.: 650.2703.001

Technical data

Voltage	10 to 30 V DC
Max output current	200 mA
Max switch frequency	800 Hz
Temperature range	-25°C to +70°C
Protective system	IP 67
Switch type	normally open
Max detection gap	2 mm

Switch diagram

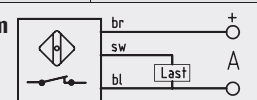

GENERAL FUNCTION

R+W torque limiters are ball detent style overload couplings. They protect drive and driven mechanical components from damage associated with torque overloads.

- Backlash free transmission torque is accomplished by a series of steel balls (4) nested in hardened detents (5).
- Disc springs push (2) against an actuation ring (3) keeping the balls nested.
- The disengagement torque is adjustable by means of an adjustment nut (1).
- In the event of an overload, the actuation ring (3) moves axially allowing the balls to roll out of the detents separating the drive and driven elements.
- The movement of the actuation ring (3) can be sensed by means of a mechanical switch or proximity sensor (6) triggering the drive to shut down.

Single-position / Multi-position / Load holding

In a torque overload, for the single-position design (standard) and multi-position design, the spring disengages to allow the balls to come out of their detents, separating the drive and driven elements. A very light residual spring pressure remains so that the coupling will re-engage once the torque is reduced below the overload setting.

In the load holding version the drive and driven elements are only allowed limited rotation in order to allow for movement of the actuation ring. (see page 4)

Re-engagement is only possible at low speed.

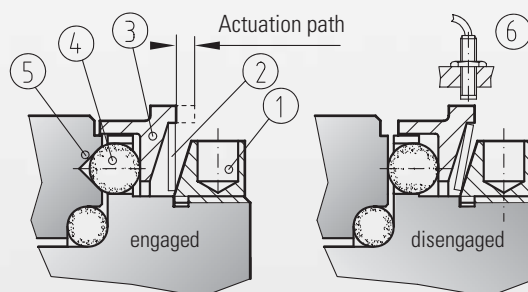

Full disengagement version

With this design, when a torque overload is detected, the disc spring completely flips over and places no residual spring pressure on the actuation ring (7). The drive and driven elements are completely separated.

Coupling will not re-engage automatically. A manual reset is required (Picture 3a, 3b).

CAUTION:
Re-engagement should only be performed when the coupling is still and not rotating!

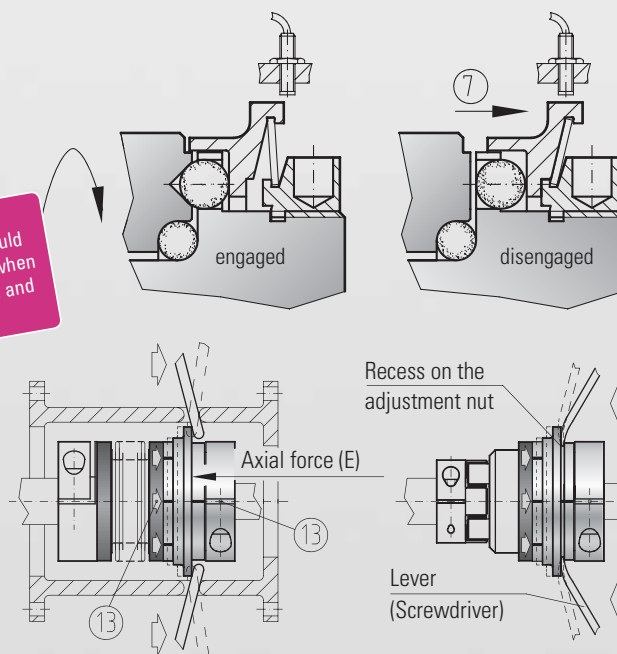

Picture 3a (up to series 60)

Picture 3b (series 60 and up)

Torque limiting portions of SK and ES2 are identical.

The R+W full disengagement torque limiter can be re-engaged in 6 different positions (every 60 degrees) with low axial force (E). Marks on the actuation ring and body (13) will line up to indicate the re-engagement points.

Re-engagement of series 60 and up can be achieved through the use of 2 levers, which are to be supported at a recess on the adjustment nut (picture 3b). Screwdrivers can be used as a lever.



single-position
multi-position
load holding
full disengagement

MOUNTING-INSTRUCTIONS

BACKLASH FREE TORQUE LIMITER

MODEL SK1 / SKN / SKP

SK1 / SKN / SKP have an integral bearing (1) for support of attached component (pulley, sprocket, etc.)

Please do not exceed the maximum radial force (2) as described in the table below.

When centering the load over the "S" dimension, additional bearing support is not required.

For offset mounting, additional bearing support is required.

This is recommended, for example, if the attached component has a very small diameter or the driven element is very wide.

Depending on the installation situation, ball bearings, needle bearings or bushings may be used.

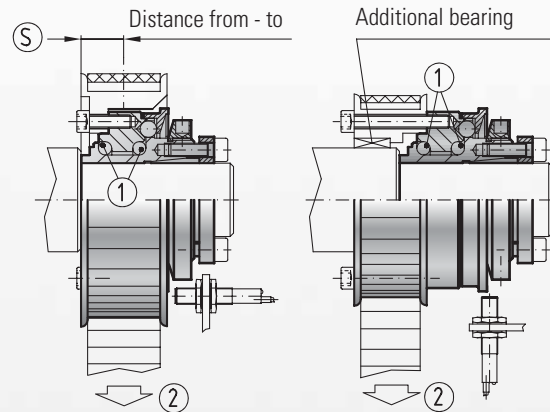

Series	1,5	2	4,5	10	15	30	60	150	200	300	500	800	1500	2500
Radial load capacity,max (N)	50	100	200	500	1400	1800	2300	3000	3500	4500	5600	8000	12000	20000
(S) from-to (mm)	3-6	5-8	5-11	6-14	7-17	10-24	10-24	12-24	12-26	12-28	16-38	16-42	20-50	28-60

Disengagement torque setting

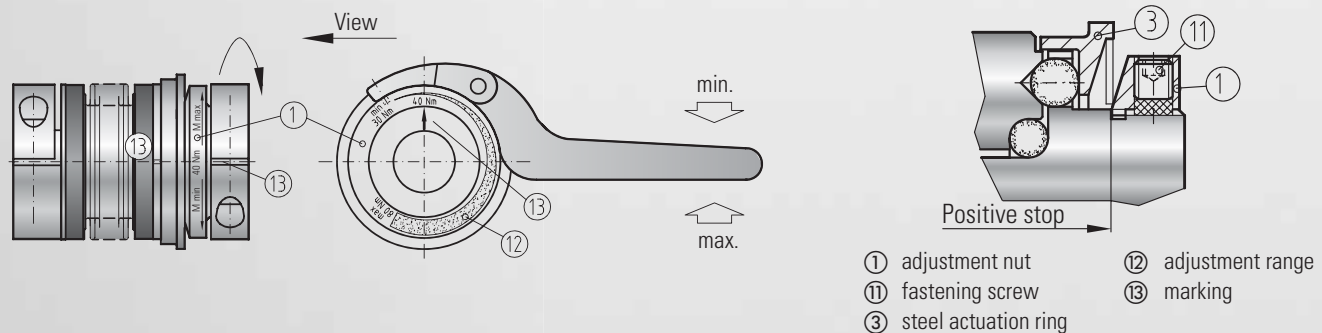

R+W torque limiters are factory set to the customer specified disengagement torque, which is marked onto the coupling. The adjustment range (min/max) is also marked on the adjustment nut (1). The customer can adjust the disengagement torque as long as it falls into the range (12) indicated on the adjustment nut.

Do not exit the adjustment range during setting.

To adjust the disengagement torque, loosen the locking screws (11) and rotate the adjustment nut, using a spanner wrench, to the desired new setting. Tighten the 3 locking screws (11) and test the coupling.

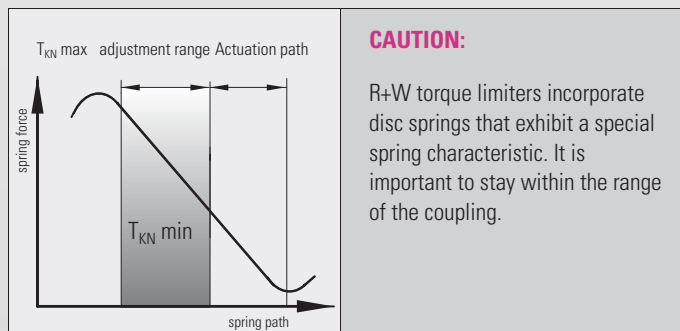



MOUNTING AND DISMOUNTING OF TORQUE LIMITERS

Mounting preparation

All mounting surfaces including shafts, bores, keys and keyways, must be clean and free of burrs, nicks and dents. Inspect shaft diameters, coupling bore diameters, key and keyway dimensions and tolerances. All R+W coupling bores are machined to ISO tolerance H7. Clearances between the shaft and hub are maintained to be within 0.01 and 0.05 mm. A light coating of oil is recommended to ease the mounting process and will not affect the clamping force of the hub.



CAUTION:

Do not use sliding grease, or oils or grease with molybdenum disulfide or other high pressure additives.

SK 1
with tapered bushing
Series 15 - 2500

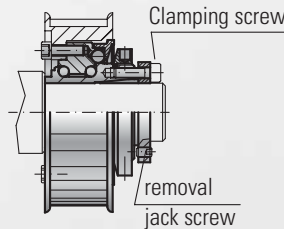

Mounting:

Slide the coupling onto the shaft to the proper axial position. Using a torque wrench, uniformly tighten the clamping screws using a cross-wise tightening pattern until all the clamping screws are evenly tightened to the correct tightening torque provided in table (page 7). During tightening the coupling may move slightly towards the tapered bushing.

Caution! Further tightening of the clamping screws may destroy the tapered bushing connection.

NOTE: Prior to reassembly make sure that the jack-screws are removed or raised to their original position.

Dismounting:

Loosen the clamping screw. Insert the three jack screws into the tapped holes on the tapered segment. Apply even pressure to remove the tapered segment. Remove the coupling.

SK 1 / SKN
with clamping hub
SK 1 Series 1.5 - 10
SKN Series 15-1500

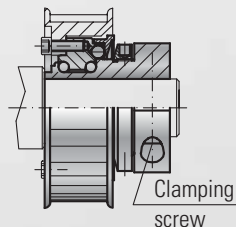

Mounting:

Slide the coupling onto the shaft to the proper axial position. Using a torque wrench tighten the clamp screw to the proper tightening torque. (page 7/9)

Dismounting:

Simply loosen the clamp screw and remove the coupling.

SKP
with keyway
Series 1.5 - 2500

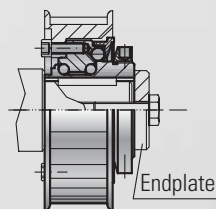

Mounting:

Slide the coupling onto the shaft. Lock it in position, with an end plate (8) for example.

Dismounting:

Remove the end plate and slide the coupling off the shaft using an appropriate tool.

Metal bellows torque limiters

SK 2
with clamping
hub

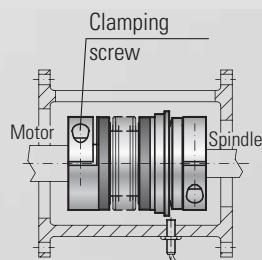

Mounting:

Prior to mounting make sure that the shafts to be connected do not exceed the angular or lateral misalignment limits for the coupling size to be used. This data can be found in the catalog. Slide the coupling on the first shaft end to the proper axial position. Using a torque wrench, tighten the clamp screw to the correct tightening torque (table page 12). Insert the second shaft into the other end of the coupling to the proper axial position. Make sure that the coupling is free of any axial forces before tightening. Tighten the clamp screw as above using a torque wrench.

Dismounting:

Simply loosen the clamp screw and remove the coupling.



single-position
multi-position
load holding
full disengagement

MOUNTING INSTRUCTIONS

MOUNTING AND DISMOUNTING OF TORQUE LIMITERS

SK 3 With tapered conical clamp

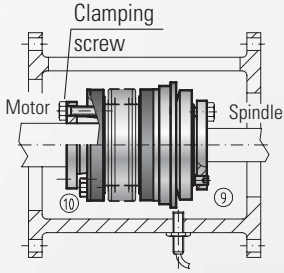

Mounting:

Prior to mounting make sure that the shafts to be connected do not exceed the angular or lateral misalignment limits for the coupling size to be used. This data can be found in the catalog. Slide the coupling onto the first shaft to the proper axial position. Using a torque wrench, uniformly tighten the clamping screws using a cross-wise tightening pattern. Apply 1/3, 2/3 and full torque until all the clamping screws are evenly tightened to the correct tightening torque (see page 13).

Dismounting:

Loosen the clamping screws. Use the three jack screws (9) conveniently mounted in the hub to evenly back out the tapered segment. Remove the coupling.

CAUTION: Mounting is completed. Further tightening of the clamp screws may damage the tapered bushing connection.

SK 5 Blind-mate with clamping hubs

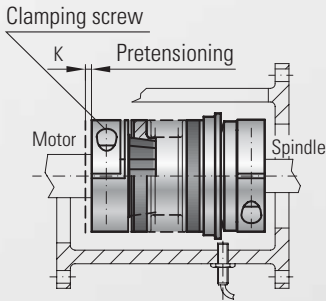

Mounting:

Prior to mounting it is necessary to consider the overall length of the assembled coupling. The press-fit coupling requires a specific pre-tensioning (K) between the two coupling halves to ensure backlash free

operation. Mount the „female“ coupling segment containing the bellow onto the first shaft end to the proper axial position. Using a torque wrench tighten the clamp screw to the proper tightening torque. Mount the „male“ coupling segment onto the second shaft end. The proper axial position is when the two couplings come together and the coupling is compressed by the proper pre-tension distance (K). See page 14. When the coupling segment is properly positioned tighten the clamp screw to the proper torque.

Dismounting:

Pull the coupling apart. Simply loosen the clamp screws and remove the coupling from the shaft.

Elastomer torque limiters

ES 2 With clamping hubs

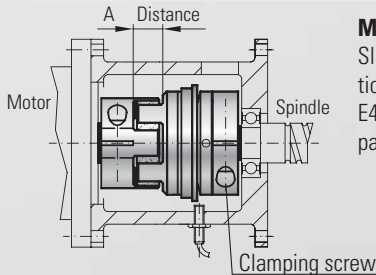

Mounting:

Slide the coupling on the shaft ends to the proper axial position. Using a torque wrench, tighten the clamp screws (E1/E4) to the correct tightening torque as indicated (in the table page 17)

Dismounting:

Simply loosen the clamp screw and remove the safety coupling.

ESL With pure keyway connection

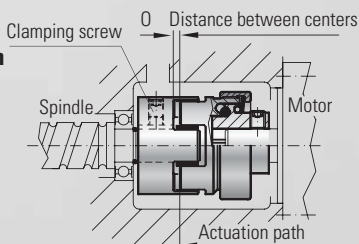

Mounting:

Slide the torque limiting portion onto the motor shaft. At the correct axial position, tighten the clamping screw (DIN 916). Repeat this step for the coupling hub on the spindle shaft.

The minimum distance O (see table on page 25) is critical during installation since the torque limiting portion will move axially upon disengagement.

The torque limiter functions according to a ratcheting principle. High-strength, hardened steel ball bearings are alternately engaged next to each other. One indexed position follows another (ratcheting).

Dismounting:

Loosen the clamping screw and remove the safety coupling.

optional
stainless steel

single-position
multi-position
load holding
full disengagement

MOUNTING AND DISMOUNTING OF TORQUE LIMITERS

The ESL torque limiter is factory preset at the required disengagement torque and is not adjustable.

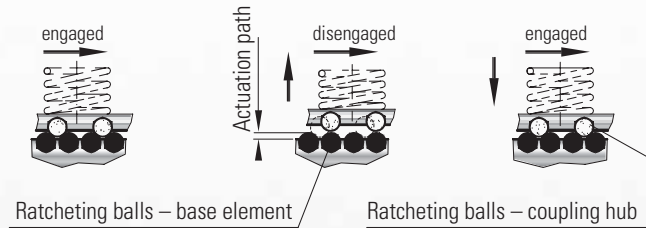

Elastomer inserts

The equalizing element of an EK coupling is the elastomer insert. It transmits the torque without backlash or vibration. The elastomer insert defines the features of the entire coupling and/or of the entire drive system. The insert is available in 2 different shore values.

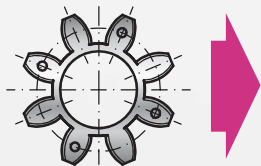

Type	Color	Shore hardness	Material	Temperature range	Features
A	red	98 Sh A	TPU	-30°C - +100°C	high damping
B	green	64 Sh D	TPU	-30°C - +120°C	high torsional stiffness

To achieve zero backlash the coupling hubs must be pressed together with an axial force compressing the elastomer ring. Cleaning the elastomer ring and hubs and applying a light film of oil will aid in the assembly process.

Caution!

Use PU – compatible greases such as petroleum jelly.

Series		5	10	20	60	150	300	450	800	
Fit length	mm	A	9	11.5	16	18	20	24	26	31
minimum distance*	mm	0	0.7	1.1	0.7	1.3	1.3	-	-	-

* Only necessary for ESL

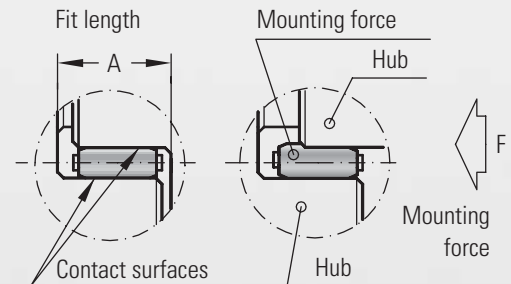

Max. misalignment

Angular misalignment ΔKw

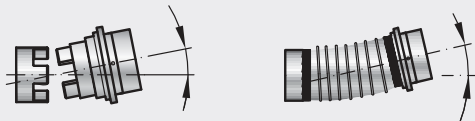

Axial misalignment ΔKa

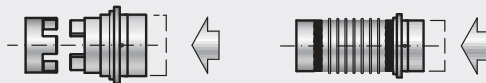

Lateral misalignment ΔKr

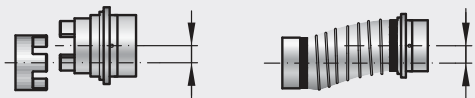

CAUTION:

Exact alignment of the R+W Torque Limiter considerably increases the service life of the metal bellows.

Reducing or eliminating lateral misalignment eliminates the radial loading of the adjacent bearings, increasing service life and reducing heat.

For drives running at high speed it is recommended to align the coupling with a dial indicator.

Max. misalignment values see table. Axial misalignment between 1-2 mm.



single-position
multi-position
load holding
full disengagement

ADDITIONAL INFORMATION

BACKLASH-FREE TORQUE LIMITERS FROM R+W

Behaviour and characteristic

Disengagement behavior

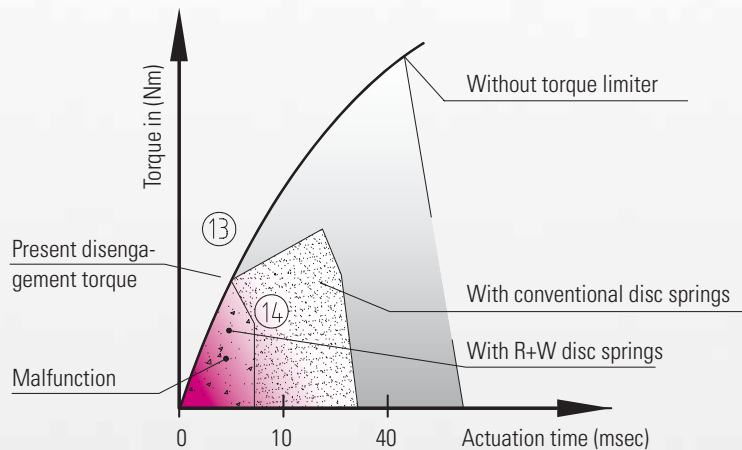

Spring characteristic

Degressive spring characteristic

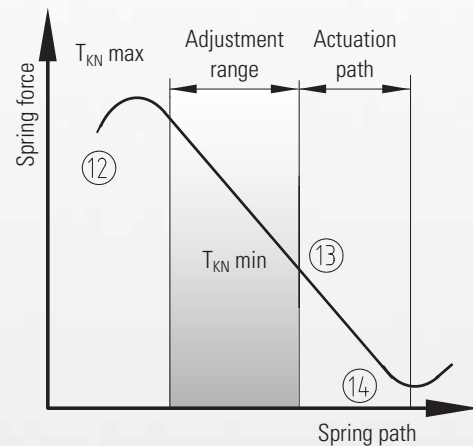

Spring package:

R + W torque limiters function by means of a disc spring with a degressive characteristic developed exclusively for this application (12).

Upon the couplings actuation, this characteristic (13) brings about an immediate drop in the torque (14) and an interruption of the force flux.

The spring force of the disc spring drops to a lower value after the disengagement process.

This advantage guarantees extremely short actuation times (1-3 ms), low wear and very low residual friction (between 2-5 %).

Speed:

The service life of the coupling is essentially determined by the number of rotations after disengagement.

Wear:

No wear occurs during engaged operating condition. In the event of an overload the drive should be stopped through a mechanical limit switch or proximity switch immediately

Maintenance:

When properly engaged, the torque limiters are wear free, and therefore require no maintenance. The ball detent mechanism within each coupling is permanently lubricated.

Seal:

Sealing of the torque limiters is available.

Torque Limiter in sealed version (Option)

Advantages of the sealing:

- Protection from dirt and liquid contamination
- Appropriate for food service and light washdown environments
- No escape of grease possible

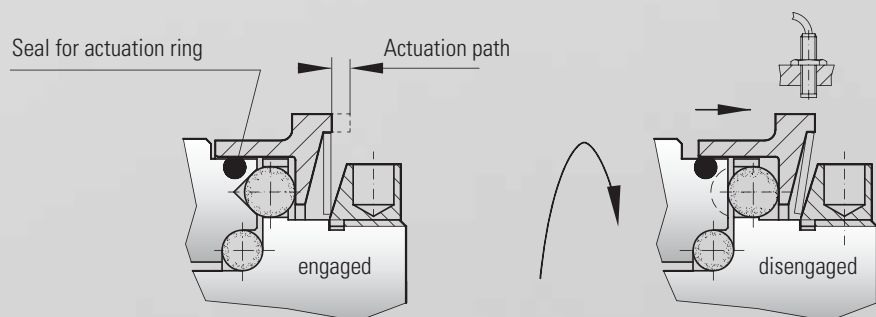

Prior technical approval is suggested for applications using our products other than specified.



single-position
multi-position
load holding
full disengagement

SELECTION

BACKLASH FREE TORQUE LIMITERS FROM R+W

According to disengagement torque

As a rule torque limiters are rated according to the required disengagement torque, which must be greater than the torque that is necessary for regular machine operation.

$$T_{KN} \geq 1.5 \cdot T_{AS} \text{ (Nm)}$$

T_{KN} = rated torque of coupling (Nm)
 T_{AS} = peak torque of motor (Nm)

The disengagement torque of the torque limiters is determined as a rule in accordance with the drive specifications.

or

$$T_{KN} \geq 9550 \cdot \frac{P_{AN}}{n} \cdot 1.5 \text{ (Nm)}$$

T_{KN} = rated torque of coupling (Nm)
 P_{AN} = drive power (kw)
 n = speed of drive (rpm)

The following calculation has proven itself as a good rule of thumb:

According to acceleration torque (start-up at no load)

S_A = shock or load factor

- $S_A = 1$ (uniform load)
- $S_A = 2$ (non-uniform load)
- $S_A = 3$ (high dynamic load)

$$T_{KN} \geq \alpha \cdot J_L \geq \frac{J_L}{J_A + J_L} \cdot T_{AS} \cdot S_A \text{ (Nm)}$$

T_{KN} = rated torque of coupling (Nm)
 α = angular acceleration $\frac{1}{s^2}$
$$\alpha = \frac{\omega}{t} = \frac{\pi \cdot n}{t \cdot 30}$$

Values for $S_A = 2-3$ are usual for servo drives on machine-tools

t = acceleration time (s)
 ω = angular speed in (s^{-1})
 n = speed of drive (rpm)
 J_L = moment of inertia on load side (kgm^2)
 J_A = moment of inertia on driving side (kgm^2)
 T_{AS} = peak torque of motor (Nm)

According to acceleration and load torque (start with load)

$$T_{KN} \geq \alpha \cdot J_L + T_{AN} \geq \left[\frac{J_L}{J_A + J_L} \cdot (T_{AS} - T_{AN}) + T_{AN} \right] \cdot S_A \text{ (Nm)}$$

S_A = shock or load factor

- $S_A = 1$ (uniform load)
- $S_A = 2$ (non-uniform load)
- $S_A = 3$ (high dynamic load)

Values for $S_A = 2-3$ are usual for servo drives on machine-tools

T_{KN} = rated torque of coupling (Nm)
 α = angular acceleration $\frac{1}{s^2}$
$$\alpha = \frac{\omega}{t} = \frac{\pi \cdot n}{t \cdot 30}$$

t = acceleration time (s)
 ω = angular speed in (s^{-1})
 n = speed of drive (rpm)
 J_L = moment of inertia on load side (kgm^2)
 T_{AN} = load torque (Nm)
 J_A = moment of inertia on driving side (kgm^2)
 T_{AS} = peak torque of motor (Nm)



single-position
multi-position
load holding
full disengagement

SELECTION

BACKLASH FREE TORQUE LIMITER

According to feed force

Spindle drive

$$T_{AN} = \frac{s \cdot F_V}{2000 \cdot \pi \cdot \eta} \text{ (Nm)}$$

T_{AN} = load torque (Nm)
 S = spindle pitch (mm)
 F_V = feed force (N)
 η = spindle efficiency

Timing belt drive

$$T_{AN} = \frac{d_0 \cdot F_V}{2000} \text{ (Nm)}$$

T_{AN} = load torque (Nm)
 d_0 = pinion dia. (pulley) (mm)
 F_V = feed force (N)

According to resonant frequency (SK 2 / 3 / 5 with bellows attachment – ES 2 / ESL with elastomer insert)

Usually high resonant frequencies of the couplings are required in order to make high acceleration values possible and to avoid excessive vibration.

For the purpose of calculation the drive is reduced to a 2 mass system.

$$f_e = \frac{1}{2 \cdot \pi} \sqrt{C_T \times \frac{J_{Masch} + J_{Mot}}{J_{Masch} \cdot J_{Mot}}} \text{ (Hz)}$$

C_T = torsional stiffness of the coupling (Nm/rad)
 $J_{Masch.}$ = moment of inertia of machine (spindle + slide + workpiece + half of coupling) (kgm²)
 $J_{Mot.}$ = moment of inertia of motor (motor's rotor + half of coupling) (kgm²)
 f_e = Resonant frequency of a two mass system (Hz)

According to torsional stiffness (SK 2 / 3 / 5 with bellows attachment – ES 2 / ESL with elastomer insert)

Transmission errors due to a torsional stress on the metal bellows:

$$\varphi = \frac{180}{\pi} \cdot \frac{T_{AS}}{C_T} \text{ (Degrees)}$$

φ = angle of turn (degrees)
 C_T = torsional stiffness of coupling (Nm/rad)
 T_{AS} = peak torque of motor (Nm)

According to the function system

Load holding version: On SK1 / SKP / SKN models the load holding version has a double load safety margin. Ensure that models with bellows (SK2, 3 and 5) are of adequate size. The overload torque in this case should not exceed the nominal torque rating of the coupling.



single-position
multi-position
load holding
full disengagement

FACTORS AND SIZING CALCULATIONS

BACKLASH FREE ELASTOMER COUPLINGS ES2 / ESL

Temperature factor S_u	A	B
Temperature (v)	Sh 98 A	Sh 64 D
> -30°C to -10°C	1,5	1,7
> -10°C to +30°C	1,0	1,0
> +30°C to +40°C	1,2	1,1
> +40°C to +60°C	1,4	1,3
> +60°C to +80°C	1,7	1,5
> +80°C to +100°C	2,0	1,8
> +100°C to +120°C	–	2,4

Start factor S_z

Z_h	up to 120	120 - 240	above 240
S_z	1,0	1,3	on request

Shock and load factor S_A

Uniform load	$S_A = 1,0$
Non-uniform load	$S_A = 1,8$
High dynamics, frequent reversing loads	$S_A = 2,5$

- T_{KN} = Rated torque of the coupling (Nm)
- T_{Kmax} = Max. torque of the coupling (Nm)
- T_S = Existing peak torque of the coupling (Nm)
- T_{AS} = Peak torque of the drive element (Nm)
- T_{AN} = Rated torque of the drive element (Nm)
- T_{LN} = Rated torque of the driven element (Nm)
- P_{LN} = Power of the driven element (KW)
- n = Speed (rpm)
- J_A = Motor's moment of inertia (kgm²)
- J_L = Machine's moment of inertia (Spindle + slide + workpiece) (kgm²)
- J_1 = Moment of inertia of a coupling half at the driving end (kgm²)
- J_2 = Moment of inertia of a coupling half at the driven end (kgm²)
- m = Ratio of the moments of inertia driving to driven element
- v = Temperature of the area around the coupling (observe radiant heat)
- S_u = Temperature factor
- S_A = Shock or load factor
- S_z = Start factor (factor for the number of starts/hour)
- Z_h = Cycle of starts (1/h)

Selection of the Elastomer Coupling

1. Calculation example without shock or reversing loads

The rated torque of the coupling (T_{KN}) needs to be higher than the rated torque of the driven element (T_{LN}) times the temperature factor S_u at the coupling for the application. If T_{LN} is not known, T_{AN} can be used for the calculation instead.

Condition:

$$T_{KN} > T_{LN} \times S_u$$

Auxiliary calculation:

$$T_{LN} = \frac{9550 \times P_{LN}}{n}$$

Calculation example: (No loads and shocks)

Drive face: DC - motor

$$T_{AN} = 119 \text{ Nm}$$

Coupling conditions:

$$v = 70^\circ \text{C}$$

$$S_u = 1,7 \text{ (for } 70^\circ \text{C/Type A)}$$

Driven face: Pump

$$T_{LN} = 85 \text{ Nm}$$

$$\text{Condition: } T_{KN} > T_{LN} \times S_u$$

$$T_{KN} > 85 \text{ Nm} \times 1,7$$

$$T_{KN} > \underline{144,5 \text{ Nm}}$$

Result: A coupling type **EK 2/150/A** ($T_{KN} = 160 \text{ Nm}$) is selected.

2. Calculation example with shock loads

In all cases the maximum rated torque (T_{Kmax}) of the coupling can not be exceeded. First calculate the rated torque (T_{KN}) of the coupling same as above. Compare this result to the peak torque (T_S) times the start factor (S_z) times the temperature factor (S_u) for the application. The greater of the two values must be less than (T_{Kmax}) of the coupling.

Condition:

$$T_{KN} > T_{LN} \times S_u$$

Auxiliary calculation:

$$T_{LN} = \frac{9550 \times P_{LN}}{n}$$

Condition:

$$T_{Kmax} > T_S \times S_z \times S_u$$

Auxiliary calculation:

$$T_S = \frac{T_{AS} \times S_A}{m + 1}$$

$$m = \frac{J_A + J_1}{J_L + J_2}$$



single-position
multi-position
load holding
full disengagement

R+W: EXPERTISE AND KNOW-HOW

BACKLASH FREE TORQUE LIMITER

Quality and know-how for couplings in servo, NC and stepper motor systems.

The demands on drive technology have dramatically and steadily increased in the past few years. Our company **R+W** is proud to have reached a leading market position within the same few short years and we continue to work hard in the areas of design and technical development to stay there. **R+W** has representatives in more than 43 countries all over the world and is opening more branches every year.

Our range of high-quality precision couplings meet the needs of the most demanding applications. But for our technical staff this is not enough. We are constantly developing, new solutions, new designs, new possibilities.

We want you to contact us, to give us the opportunity to create a solution and to earn your business. Each person on the **R+W** staff knows that quality comes from his or her personal engagement with, and listening to, the customer.

Benefit from our quality and efficiency.

We are ISO 9001 certified. Our production and customer service department have been organized to maximize efficiency and minimize delivery time.

Extensive quantities of component inventory are kept on hand to ensure the quickest possible delivery, often within one day. Special designs are a major part of our business and are immediately processed, designed and built. **R+W** also has developed proprietary software to calculate resonant frequencies and other performance limits.

R+W continues to reinvest to ensure that our couplings remain innovative to improve their efficiency and operating dependability with your applications.



R+W: First Manufacturer of Safety Coupling with TÜV-Certificate

The complete line of R+W torque limiters were put through a complex test by TÜV Süd and met all the requirements for certification. The tests included normal wear, number of disengagements, precision of disengagement torque setting, and overall function and safety. During testing, overload events were simulated through active changes in the operating torque and running speed during operation.

Test result: The torque limiters meet all the requirements of the German GPSG law, an objective of the EG-directive.



Special low cost rust protection process

Corrosion protection which is equivalent to that of galvanized or chrome-plated surfaces is available.

The positive features of this include good resistance to wear and corrosion.

The parts are resistant to a salt spray test pursuant to DIN 50021 for a period of 140 hours.

This process represents a genuine, low cost alternative to expensive stainless steel materials.

Couplings with this surface treatment have been used for many years by well-known companies in the food industry.



Download

All 2D and 3D drawings can be downloaded directly from our website: www.rwcouplings.com.



DIN ISO 9001

Quality awareness is a high priority at R+W.

The introduction of DIN ISO 9001 has meant the refinement of quality procedures and the appropriate documentation.

In a one-year preparation period, the ISO 9001 quality system was produced and certified on 4 March 1997.

Constant monitoring and improvement of the system ensures a technically superior product with a quality standard second to none.

optional
stainless steel

single-position
multi-position
load holding
full disengagement

PRODUCT DEVELOPMENT

More compact and higher torque capacity

The trend for safety couplings in the coming years will call for a more compact, higher torque capacity model. This becomes possible through the use of special materials, as well as the implementation of new procedures and techniques in manufacturing and the production of individual components.

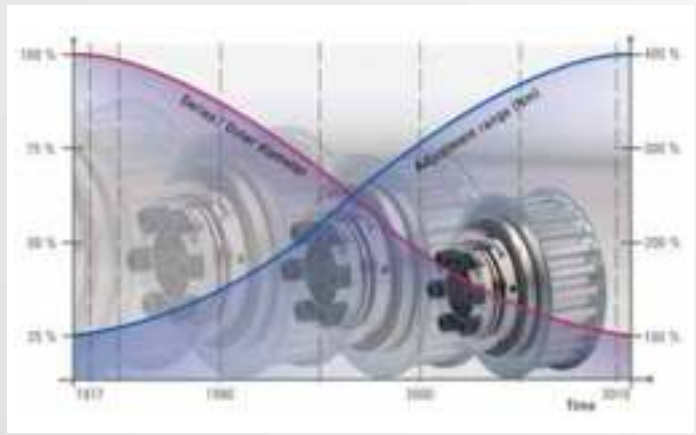

Fiberglass reinforced high-strength plastic

After the successful introduction of alternative materials such as fiberglass reinforced thermoplastic to precision couplings, it becomes realistic to offer torque limiters, either partially or entirely out of fiberglass reinforced plastic in the near future. High-strength plastic materials provide the mechanical designer with additional freedom in the layout of the machine compared to standard materials such as aluminum or steel.

New product line ST from 1,000 – 160,000 Nm

The implementation of an ST torque limiter minimizes machine downtime, resulting in an increase in production capacity. The ST torque limiters are designed for high torque applications. This is possible through equally positioned torque modules around the circumference of the base element.



ST 1

Torque Limiter for indirect drives

- Compact, simple design
- Precise overload protection
- Torsionally rigid
- Integral bearings for timing belt, pulley or sprocket



ST 2

Torque Limiter for direct drives

- Compensation for misalignment
- Precise overload protection
- Vibration damping



ST 3

Torque Limiter for direct drives

- Torsionally rigid
- Compensation for misalignment
- Precise overload protection



ST 4

Torque Limiter with gear coupling

- High power density
- Compensations for misalignment
- Low restoring force
- Resilient

Request a copy of the complete ST catalog today!

**Experience and
 Know-how
 for your special
 requirements.**

R+W America
 1120 Tower Lane
 Bensenville, IL 60106

Phone: 630-521-9911
 Fax: 630-521-0366

info@rw-america.com
 www.rw-america.com



TGA-ZM-05-91-00
 Registration No. 40503432/2

The information mentioned in this document is based on our present knowledge and experiences and does not exclude the manufacturer's own substantial testing of the equipment. So this is no obligatory assurance even with regard to protection rights of Third Parties. The sale of our products is subject to our General Conditions of Sale and Delivery.

THE R+W-PRODUCT RANGE



TORQUE LIMITERS
Series SK + ST

From 0.1 – 160,000 Nm, Bore diameters 3 – 290 mm
 Available as a single position, multi-position, load holding, or full disengagement version
 Single piece or press-fit design



BELLOWS COUPLINGS
Series BK / BX

From 2 – 100,000 Nm
 Bore diameters 10 – 280 mm
 Single piece or press-fit design



LINE SHAFTS
Series ZA /ZAE /EZ /EZV

From 10 – 25,000 Nm
 Bore diameters 5 – 140 mm
 Available up to 6 m length



MINIATURE BELLOWS COUPLINGS
Series MK

From 0.05 – 10 Nm
 Bore diameters 1 – 28 mm
 Single piece or press-fit design



SERVOMAX®
ELASTOMER COUPLINGS
Series EK

From 2 – 25,000 Nm, Shaft diameters 3 – 170 mm
 backlash-free, press-fit design



ECOLIGHT®
ELASTOMER COUPLINGS
Series TX 1

From 2 – 810 Nm
 Shaft diameters 3 – 45 mm



LINEAR COUPLINGS
Series LK

From 70 – 2,000 N
 Thread M5 – M16



POLYAMIDE COUPLINGS
MICROFLEX
Series FK 1

Rated torque 1 Ncm
 Bore diameters 1 – 1.5 mm