



TECHNICO INC

766 North River Road NW
Warren, OH 44483

eShaft case 60



Linear Shafting



Motion Control Products
For Industrial Automation

Contact us at:
PH: (330) 847-7000

www.eShaft.com



For over two decades, Technico has been a leader in the motion control industry. Our team has focused on what matters – the highest quality products with the best customer service.

- eShaft Case 60 Linear Shafting is induction hardened, precision ground, and polished to the tolerances required by the demanding Linear Motion Industry
- Linear Shafting Industry Class "L", "S", "N" and "D"
- Inch sizes of Linear Shafting (1/4" - 4" Diameters)
- Metric sizes of Linear Shafting (6mm - 100mm Diameters)
- Pre-Drilled Linear Shafting (1/2" - 2" Diameters)
- Stainless Steel Linear Shafting
- Standard Aluminum Support Rails, Low Profile Steel Support Rails
- Complete Selection of Linear Bearings, Pillow Blocks and End Supports
- Custom machining to your print and special coatings available
- See our website for the complete product line

eSHAFT SPECS

Material – High quality Carbon 1060 or Stainless 440C produced in the U.S.

Case Hardness – Varies by material type - See Chart

Surface Finish – 8 RMS

Roundness – Industry Superior

Cylindricity – Industry Superior

Straightness – .001 per foot cumulative, (TIR .002")

www.eShaft.com

CONTENTS	PAGE NUMBER
About eShaft	2
Inch Linear Shafting	4
Metric Linear Shafting	5
Predrilled Linear Shafting	6
Shaft Support Rails	7
Low Shaft Support Rails	8
Custom Machining	9
Linear Bearing Overview	10
Linear Bearing Dimensions	11-19
Shaft End Supports	20
About Technico	23
Technico Line Card	24

COMPOSITION OF PART NUMBERS

ES	0.625	SS +	25	S
Shaft Type	Diameter	Material <small>(Blank for Regular 1060)</small>	Length <small>(In Inches or MM for metric Shafting)</small>	Accuracy Class <small>(Blank for Standard L Class)</small>

PREDRILLED SHAFTING AND ASSEMBLIES

ES	0.750	PD + XX	- Predrilled Shaft Only
ESSR	0.750	PD + XX	- Predrilled Shaft Support Rail Only
ES	0.750	PD + XX Assembly	- Predrilled Shaft Mounted to Support
ES	0.750	PD + XX Low Assembly	- Predrilled Shaft Mounted to Low Support

XX = Length in inches or mm

INCH LINEAR SHAFTING

INCH LINEAR SHAFTING – 1060 STEEL SURFACE HARDNESS RC60-63

PART NUMBER	NOMINAL DIA. (IN)	CLASS L	CLASS S	CLASS N	CLASS D	MAX LENGTH (IN)
ES 0.250	1/4	.2495/.2490	.2490/.2485	.2500/.2498		94
ES 0.375	3/8	.3745/.3740	.3740/.3735	.3750/.3748	–	166
ES 0.500	1/2	.4995/.4990	.4990/.4985	.5000/.4998	–	166
ES 0.625	5/8	.6245/.6240	.6240/.6235	.6250/.6248	–	178
ES 0.750	3/4	.7495/.7490	.7490/.7485	.7500/.7498	–	202
ES 0.875	7/8	.8745/.8740	–	.8750/.8748	–	178
ES 1.000	1	.9995/.9990	.9990/.9985	1.0000/.9998	1.0000/1.003	202
ES 1.125	1-1/8	1.1245/1.1240	–	1.1250/1.1248	–	178
ES 1.250	1-1/4	1.2495/1.2490	1.2490/1.2485	1.2500/1.2498	1.2500/1.2503	202
ES 1.375	1-3/8	1.3745/1.3740	–	1.3750/1.3747	–	178
ES 1.500	1-1/2	1.4994/1.4989	1.4989/1.4984	1.5000/1.4997	1.5000/1.5003	202
ES 1.625	1-5/8	1.6245/1.6240	–	1.6250/1.6247	–	178
ES 1.750	1-3/4	1.7495/1.7490	–	1.7500/1.7497	–	178
ES 2.000	2	1.9994/1.9987	1.9987/1.9980	2.0000/1.9997	2.0000/2.0003	202
ES 2.500	2-1/2	2.4993/2.4985	2.4985/2.4977	2.5000/2.4996	–	202
ES 3.000	3	2.9992/2.9983	2.9983/2.9974	3.0000/2.9996	–	202
ES 3.500	3-1/2	3.4990/3.4980	–	–	–	202
ES 4.000	4	3.9988/3.9976	3.9976/3.9964	–	–	202

Class L is standard

INCH LINEAR SHAFTING – 440C STEEL SURFACE HARDNESS RC50-55

PART NUMBER	NOMINAL DIA. (IN)	CLASS L	CLASS S	MAX LENGTH (IN)
ES 0.250 SS	1/4	.2495/.2490	.2490/.2485	54
ES 0.375 SS	3/8	.3745/.3740	.3740/.3735	166
ES 0.500 SS	1/2	.4995/.4990	.4990/.4985	166
ES 0.625 SS	5/8	.6245/.6240	.6240/.6235	178
ES 0.750 SS	3/4	.7495/.7490	.7490/.7485	178
ES 1.000 SS	1	.9995/.9990	.9990/.9985	178
ES 1.250 SS	1-1/4	1.2495/1.2490	1.2490/1.2485	178
ES 1.500 SS	1-1/2	1.4994/1.4989	1.4989/1.4984	178
ES 2.000 SS	2	1.9994/1.9987	1.9987/1.9980	178
ES 2.500 SS	2-1/2	2.4993/2.4985	2.4985/2.4977	178

METRIC LINEAR SHAFTING

METRIC LINEAR SHAFTING – 1060 STEEL SURFACE HARDNESS RC60-63

PART NUMBER	NOMINAL DIA. (MM)	CLASS M (H6)	MAX LENGTH (MM)	MAX LENGTH (IN)
ESM 5	5	.1969/.1965	1905	75
ESM 8	8	.3150/.3146	4216	166
ESM 10	10	.3937/.3933	4216	166
ESM 12	12	.4724/.4720	4216	166
ESM 16	16	.6299/.6295	4521	178
ESM 20	20	.7874/.7869	5130	202
ESM 25	25	.9843/.9838	5130	202
ESM 30	30	1.1811/1.1806	4521	178
ESM 35	35	1.3780/1.3773	6000	236
ESM 40	40	1.5748/1.5743	4521	178
ESM 50	50	1.9685/1.9679	5130	202
ESM 60	60	2.3622/2.3615	4521	178
ESM 80	80	3.1496/3.1489	5130	202

METRIC LINEAR SHAFTING – 440C STAINLESS SURFACE HARDNESS RC50-55

PART NUMBER	NOMINAL DIA. (MM)	CLASS M (H6)	MAX LENGTH (MM)	MAX LENGTH (IN)
ESM 5 SS	5	.1969/.1965	1905	75
ESM 8 SS	8	.3150/.3146	4216	166
ESM 10 SS	10	.3937/.3933	4216	166
ESM 12 SS	12	.4724/.4720	4216	166
ESM 16 SS	16	.6299/.6295	4521	178
ESM 20 SS	20	.7874/.7869	5130	202
ESM 25 SS	25	.9843/.9838	5130	202
ESM 30 SS	30	1.1811/1.1806	4521	178
ESM 40 SS	40	1.5748/1.5743	4521	178
ESM 50 SS	50	1.9685/1.9679	5130	202
ESM 60 SS	60	2.3622/2.3615	4521	178

PREDRILLED LINEAR SHAFTING

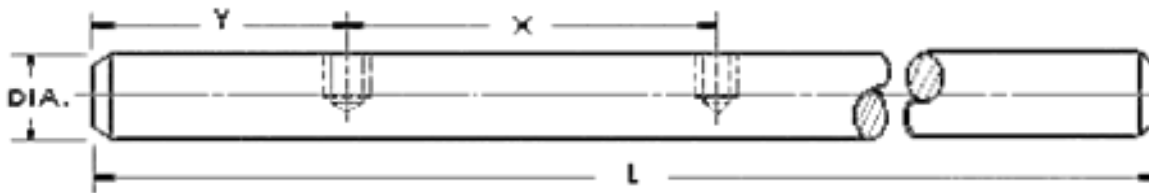

PREDRILLED LINEAR SHAFTING – 1060 STEEL

PART NUMBER	NOMINAL DIA. (IN)	CLASS "L" DIA. (IN)	STANDARD THREAD SIZE	X (IN)	Y (IN)	MAX LENGTH (IN)
ES 0.500 PD	1/2	.4995/.4990	#6-32	4	2	166
ES 0.625 PD	5/8	.6245/.6240	#8-32	4	2	178
ES 0.750 PD	3/4	.7495/.7490	#10-32	6	3	178
ES 1.000 PD	1	.9995/.9990	1/4-20	6	3	178
ES 1.250 PD	1-1/4	1.2495/1.2490	5/16-18	6	3	178
ES 1.500 PD	1-1/2	1.4994/1.4989	3/8-16	8	4	178
ES 2.000 PD	2	1.9994/1.9987	1/2-13	8	4	178

PREDRILLED LINEAR SHAFTING – 440C STAINLESS

PART NUMBER	NOMINAL DIA. (IN)	CLASS "L" DIA. (IN)	STANDARD THREAD SIZE	X (IN)	Y (IN)	MAX LENGTH (IN)
ES 0.500 PDSS	1/2	.4995/.4990	#6-32	4	2	166
ES 0.625 PDSS	5/8	.6245/.6240	#8-32	4	2	178
ES 0.750 PDSS	3/4	.7495/.7490	#10-32	6	3	178
ES 1.000 PDSS	1	.9995/.9990	1/4-20	6	3	178
ES 1.250 PDSS	1-1/4	1.2495/1.2490	5/16-18	6	3	178
ES 1.500 PDSS	1-1/2	1.4994/1.4989	3/8-16	8	4	178
ES 2.000 PDSS	2	1.9994/1.9987	1/2-13	8	4	178

SHAFT SUPPORT RAILS

PREDRILLED SHAFT SUPPORT RAILS

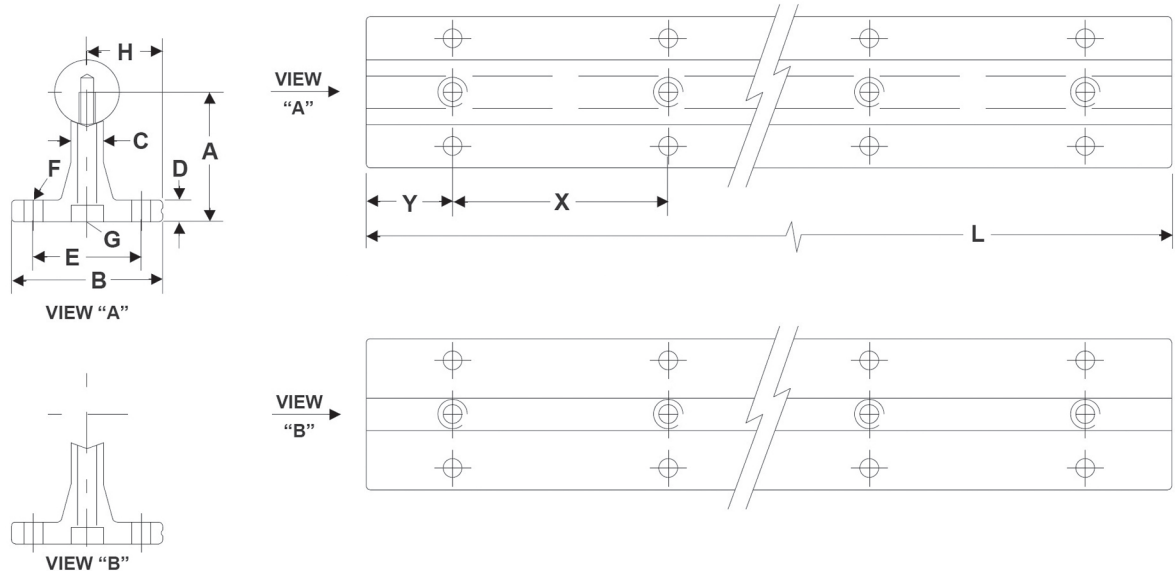

PREDRILLED SHAFT SUPPORT RAILS

Note: Shaft Support Rails and Linear Shafting are separate parts numbers, not assemblies

PREDRILLED SHAFT SUPPORT RAIL	SHAFT DIA.	A +/- .001	B	C	D	E +/- .005	F BOLT	F HOLE	G SCREW	G HOLE	H +/- .001	X	Y
ESSR 0.500 PD	1/2	1.125	1-1/2	1/4	3/16	1.000	6	.169	6-32 X 7/8	.169	.750	4	2
ESSR 0.625 PD	5/8	1.125	1-5/8	5/16	1/4	1.125	8	.193	8-32 X 7/8	.193	.812	4	2
ESSR 0.750 PD	3/4	1.500	1-3/4	3/8	1/4	1.250	10	.221	10-32 X 1-1/4	.221	.875	6	3
ESSR 1.000 PD	1	1.750	2-1/8	1/2	1/4	1.500	1/4	.281	1/4-20 X 1-1/2	.281	1.062	6	3
ESSR 1.250 PD	1-1/4	2.125	2-1/2	9/16	5/16	1.875	5/16	.343	5/16-18 X 1-3/4	.343	1.250	6	3
ESSR 1.500 PD	1-1/2	2.500	3	11/16	3/8	2.250	5/16	.343	3/8-16 X 2	.406	1.500	8	4
ESSR 2.000 PD	2	3.250	3-3/4	7/8	1/2	2.750	3/8	.406	1/2-13 X 2-1/2	.531	1.875	8	4

To Order a Predrilled Assembly with Mounted Shaft and Rail see Page 3 Composition of Part Numbers

PREDRILLED LOW SHAFT SUPPORT RAILS



PREDRILLED LOW SHAFT SUPPORT RAILS

Note: Shaft Support Rails and Linear Shafting are separate parts numbers, not assemblies

LOW PREDRILLED SHAFT SUPPORT RAIL	SHAFT DIA.	A +/- .001	B	C	E	G SCREW	G HOLE	X	Y
ESLSR 0.500 PD	1/2	.562	.370	1/4	.341	6-32	.169	4	2
ESLSR 0.625 PD	5/8	.687	.450	5/16	.412	8-32	.193	4	2
ESLSR 0.750 PD	3/4	.750	.510	3/8	.420	10-32	.221	6	3
ESLSR 1.000 PD	1	1.000	.690	1/2	.560	1/4-20	.281	6	3
ESLSR 1.250 PD	1-1/4	1.187	.780	9/16	.626	5/16-18	.343	6	3
ESLSR 1.500 PD	1-1/2	1.375	.930	11/16	.703	3/8-16	.406	8	4
ESLSR 2.000 PD	2	1.750	1.180	7/8	.845	1/2-13	.531	8	4

To Order a Predrilled Assembly with Mounted Shaft and Rail see Page 2 Composition of Part Numbers

MACHINED ENDS

Below are some of the most common types of machined ends available. Eshaft can provide special shaft machining for all your linear shafting needs.



RADIAL FLAT(S)



O.D. THREADED



CLEVIS MOUNT END

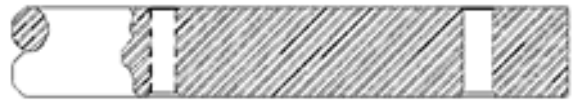

TAPPED OR DRILLED RADIALLY THRU.



SNAP RING GROOVE(S)

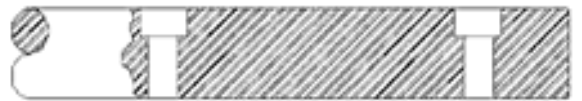

COUNTERBORED THRU HOLE(S)



REDUCED DIA.(S) WITH/WITHOUT KEYWAY

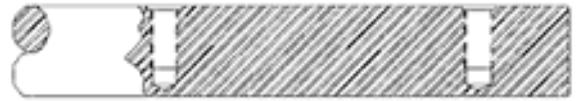

RADIAL TAPPED BLIND HOLES



REDUCED DIA. WITH THREADED END



AXIALLY DRILLED AND TAPPED END(S)

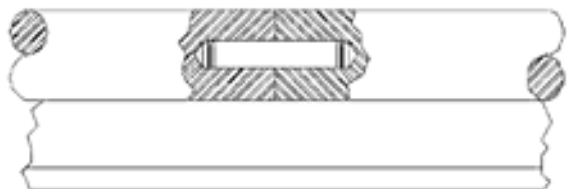

SHAFT RAIL ASSEMBLIES DOWEL JOINED

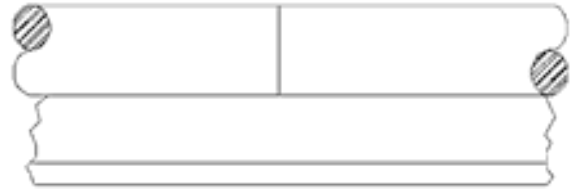

SHAFT RAIL ASSEMBLIES BUTT JOINED

TOPBALL PRODUCTS

INCH

TW
SW
SWA

METRIC

TK
SM
SMA



SLIDE BUSH



SLIDE UNIT



Please visit our website at www.eshaft.com for **METRIC BEARINGS** and other available bushing types.

TW / TW-OP TYPE – TOPBALL INCH TYPE

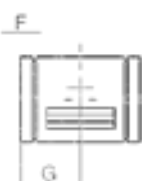
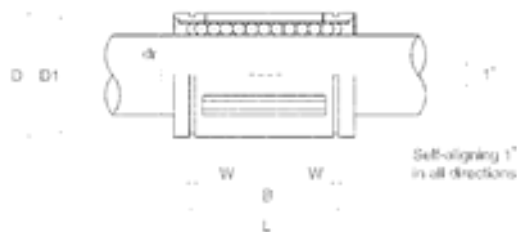

TW 8-OP



TW 10-OP



TW 12-OP thru TW32-OP

PART NUMBER						MAJOR DIMENSIONS				
CLOSED TYPE			OPEN TYPE			DR		D INCH	L	
TW	NO. OF BALL CIRCUITS	MASS LBS		NO. OF BALL CIRCUITS	MASS LBS	INCH	TOLERANCE* INCH		INCH	TOLERANCE INCH
TW 3	4	.004	-	-	-	.1875	0 -.0005	.3750	.562	±.008
TW 4	4	.009	-	-	-	.2500		.5000	.750	0 -.015
TW 6	4	.014	-	-	-	.3750		.6250	.875	
TW 8	4	.043	TW 8-OP	3	.033	.5000		.8750	1.250	0 -.020
TW 10	5	.103	TW 10-OP	4	.083	.6250		1.1250	1.500	
TW 12	6	.123	TW 12-OP	5	.102	.7500		1.2500	1.625	
TW 16	6	.265	TW 16-OP	5	.220	1.0000	1.5625	2.250	0 -.0006	
TW 20	6	.485	TW 20-OP	5	.419	1.2500	2.0000	2.625		0/- .025
TW 24	6	.750	TW 24-OP	5	.639	1.5000	2.3750	3.0000		0/- .030
TW 32	6	1.411	TW 32-OP	5	1.168	2.0000	0/- .0008	3.0000	4.0000	0/- .040

PART NUMBER		MAJOR DIMENSIONS								BASIC LOAD RATING		NOMINAL SHAFT DIAMETER INCH
CLOSED TYPE	OPEN TYPE	B		W INCH	D INCH	OPEN TYPE				DYNAMIC C INCH	DYNAMIC C ₀ INCH	
		INCH	TOLERANCE INCH			h INCH	F INCH	G INCH	J INCH			
TW 3	-	-	-	-	-	-	-	-	-	35	47	3/16
TW 4	-	.515	0 -.015	.0390	.4687	-	-	-	-	60	80	1/4
TW 6	-	.703		.0390	.5880	-	-	-	-	95	120	3/8
TW 8	TW 8-OP	1.032	0 -.020	.0459	.8209	.313	.136	.6250	THROUGH	230	290	1/2
TW 10	TW 10-OP	1.112		.0559	1.0590	.375	.105	.1250	.0390	400	500	5/8
TW 12	TW 12-OP	1.272		.0559	1.1760	.438	.136	.1250	.0590	470	590	3/4
TW 16	TW 16-OP	1.886		.0679	1.4687	.563	.136	.1250	.0470	850	1,060	1
TW 20	TW 20-OP	2.011	0/- .025	.0679	1.8859	.625	.201	.1875	.0900	1,230	1,530	1-1/4
TW 24	TW 24-OP	2.422	0/- .030	.0859	2.2389	.750	.201	.1875	.0900	1,480	1,850	1-1/2
TW 32	TW 32-OP	3.206	0/- .040	.1029	2.8379	1.000	.265	.3125	THROUGH	2,430	3,040	2

1 inch = 25.4 mm 1 lb ≈ .454 kg 1 lbs ≈ 4.448 N

TWA TYPE – BLOCK TYPE (INCH SERIES)

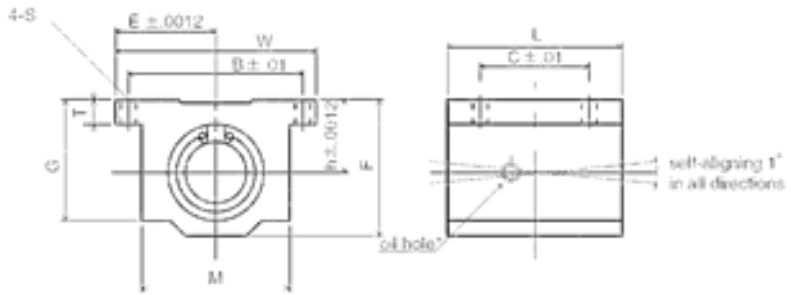

PART NUMBER	NOM. SHAFT DIA INCH	MAJOR DIMENSIONS								MOUNTING DIMENSIONS			BASIC LOAD RATING		MASS LBS
		h INCH	E INCH	W INCH	L INCH	F INCH	T INCH	G INCH	M INCH	B INCH	C INCH	S INCH	DYNAMIC C LBS	STATIC C ₀ LBS	
TWA 4UU	1/4	.4370	.8125	1.625	1.188	.813	.188	.750	1.000	1.312	.750	.156	60	80	.090
TWA 6UU	3/8	.5000	.8750	1.750	1.313	.938	.188	.875	1.125	1.437	.875	.156	95	120	.120
TWA 8UU	1/2	.6870	1.0000	2.000	1.688	1.250	.250	1.125	1.375	1.688	1.000	.156	230	290	.248
TWA 10UU	5/8	.8750	1.2500	2.500	1.938	1.625	.281	1.437	1.750	2.125	1.125	.188	400	500	.465
TWA 12UU	3/4	.9370	1.3750	2.750	2.063	1.750	.313	1.563	1.875	2.375	1.250	.188	470	590	.553
TWA 16UU	1	1.1870	1.6250	3.250	2.813	2.188	.375	1.938	2.375	2.875	1.750	.219	850	1060	1.200
TWA 20UU	1-1/4	1.5000	2.0000	4.000	3.625	2.813	.438	2.500	3.000	3.500	2.000	.219	1230	1530	2.380
TWA 24UU	1-1/2	1.7500	2.3750	4.750	4.000	3.250	.500	2.875	3.500	4.125	2.500	.281	1480	1850	3.460
TWA 32UU	2	2.1250	3.0000	6.000	5.000	4.063	.625	3.625	4.500	5.250	3.250	.406	2430	3040	6.830

* Provided with push-in oil fitting for 1/4" to 1/2" sizes. Sizes from 5/8" to 2" offer a 1/4-28 tapped hole with a plug for adding a fitting if desired. 1 inch = 25.4 mm 1 lb ≈ .454 kg 1 lbs ≈ 4.448 N

TWD TYPE – OPEN BLOCK TYPE (INCH SERIES)

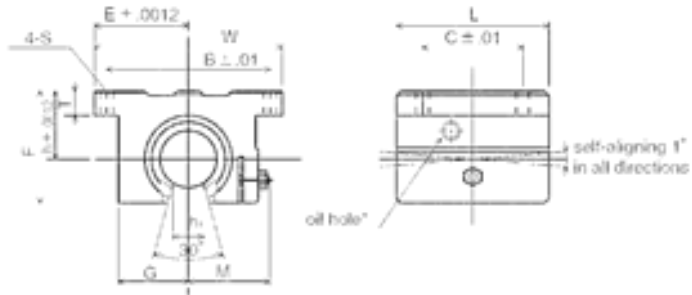

PART NUMBER	NOM. SHAFT DIA INCH	MAJOR DIMENSIONS								MOUNTING DIMENSIONS			BASIC LOAD RATING		MASS LBS	
		h INCH	E INCH	W INCH	L INCH	F INCH	T INCH	G INCH	M INCH	h ₁ INCH	B INCH	C INCH	S INCH	DYNAMIC C LBS		STATIC C ₀ LBS
TWD 8UU	1/2	.6870	1.000	2.000	1.500	1.100	.250	.688	.98	.260	1.688	1.000	.156	230	290	.188
TWD 10UU	5/8	.8750	1.2500	2.500	1.750	1.405	.281	.875	1.15	.319	2.125	1.125	.188	400	500	.365
TWD 12UU	3/4	.9370	1.3750	2.750	1.975	1.535	.315	.937	1.23	.386	2.375	1.250	.188	470	590	.452
TWD 16UU	1	1.1870	1.6250	3.250	2.625	1.975	.375	1.188	1.48	.512	2.875	1.750	.218	850	1060	1.010
TWD 20UU	1-1/4	1.5000	2.0000	4.000	3.375	2.485	.437	1.500	1.88	.569	3.500	2.000	.218	1230	1530	1.980
TWD 24UU	1-1/2	1.7500	2.3750	4.750	3.750	2.910	.500	1.750	2.12	.681	4.125	2.500	.281	1480	1850	2.950
TWD 32UU	2	2.1250	3.0000	6.000	4.750	3.660	.625	2.250	2.70	.933	5.250	3.250	.406	2430	3040	5.840

* Provided with push-in oil fitting for 1/4" to 1/2" sizes. Sizes from 5/8" to 2" offer a 1/4-28 tapped hole with a plug for adding a fitting if desired. 1 inch = 25.4 mm 1 lb ≈ .454 kg 1 lbs ≈ 4.448 N

TWJ TYPE – CLEARANCE ADJUSTABLE BLOCK TYPE (INCH SERIES)

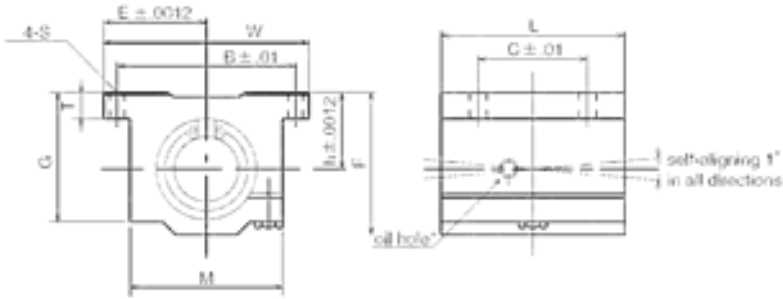

PART NUMBER	NOM. SHAFT DIA INCH	MAJOR DIMENSIONS								MOUNTING DIMENSIONS			BASIC LOAD RATING		MASS LBS
		h INCH	E INCH	W INCH	L INCH	F INCH	T INCH	G INCH	M INCH	B INCH	C INCH	S INCH	DYNAMIC C LBS	STATIC Co LBS	
TWJ 4UU	1/4	.4370	.8125	1.625	1.188	.813	.188	.750	1.000	1.312	.750	.156	60	80	.090
TWJ 6UU	3/8	.5000	.8750	1.750	1.313	.938	.188	.875	1.125	1.437	.875	.156	95	120	.120
TWJ 8UU	1/2	.6870	1.0000	2.000	1.688	1.250	.250	1.125	1.375	1.688	1.000	.156	230	290	.248
TWJ 10UU	5/8	.8750	1.2500	2.500	1.938	1.625	.281	1.437	1.750	2.125	1.125	.188	400	500	.465
TWJ 12UU	3/4	.9370	1.3750	2.750	2.063	1.750	.313	1.563	1.875	2.375	1.250	.188	470	590	.553
TWJ 16UU	1	1.1870	1.6250	3.250	2.813	2.188	.375	1.938	2.375	2.875	1.750	.219	850	1060	1.200
TWJ 20UU	1-1/4	1.5000	2.0000	4.000	3.625	2.813	.438	2.500	3.000	3.500	2.000	.219	1230	1530	2.380
TWJ 24UU	1-1/2	1.7500	2.3750	4.750	4.000	3.250	.500	2.875	3.500	4.125	2.500	.281	1480	1850	3.460
TWJ 32UU	2	2.1250	3.0000	6.000	5.000	4.063	.625	3.625	4.500	5.250	3.250	.406	2430	3040	6.830

* Provided with push-in oil fitting for 1/4" to 1/2" sizes. Sizes from 5/8" to 2" offer a 1/4-28 tapped hole with a plug for adding a fitting if desired.

1 inch = 25.4 mm

1 lb ≈ .454 kg

1 lbs ≈ 4.448 N

SWA TYPE – BLOCK TYPE (INCH SERIES)

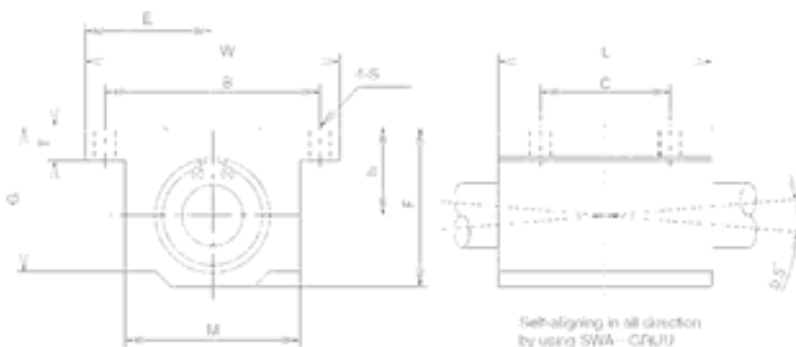

PART NUMBER	MAJOR DIMENSIONS							
	INNER CONTACT DIAMETER		OUTER DIMENSIONS					
	INCH/MM	TOLERANCE INCH/MM	h ±.001/±.002 INCH/MM	E ±.001/±.002 INCH/MM	W INCH/MM	L INCH/MM	F INCH/MM	T INCH/MM
SWA 4GUU	.2500 6.350	0 -0.0040	.4370 11.100	.8125 20.638	1.625 41.28	1.188 30.16	.813 20.64	.188 4.76
SWA 6GUU	.3750 9.525		.5000 12.700	.8750 22.225	1.750 44.45	1.313 33.34	.938 23.82	.188 4.76
SWA 8GUU	.5000 12.700	0 -9	.6870 17.450	1.0000 25.400	2.000 50.80	1.688 42.86	1.250 31.75	.250 6.35
SWA 10GUU	.6250 15.875	0 -0.0040	.8750 22.225	1.2500 31.750	2.500 63.50	1.938 49.21	1.625 41.28	.281 7.14
SWA 12GUU	.7500 19.050		.9370 23.800	1.3750 34.925	2.750 69.85	2.063 52.39	1.750 44.45	.313 7.94
SWA 16GUU	1.0000 25.400	0 -10	1.1870 30.150	1.6250 41.275	3.250 82.55	2.813 71.44	2.188 55.56	.375 9.53
SWA 20GUU	1.2500 31.750	0 -0.0050	1.5000 38.100	2.0000 50.800	4.000 101.60	3.625 92.08	2.813 71.44	.438 11.11
SWA 24GUU	1.5000 38.100		1.7500 44.450	2.3750 60.325	4.750 120.65	4.000 101.60	3.250 82.55	.500 12.70
SWA 32GUU	2.0000 50.800	0 -12	2.1250 53.975	3.0000 76.200	6.000 152.40	5.000 127.00	4.063 103.19	.625 15.88

MAJOR DIMENSIONS					BASIC LOAD RATING		MASS G	PART NUMBER
INNER CONTACT DIAMETER		MOUNTING DIMENSION			DYNAMIC C N	STATIC Co N		
G INCH/MM	M INCH/MM	B ±.01/±.02 INCH/MM	C ±.01/±.02 INCH/MM	S INCH/MM				
.750 19.05	1.000 25.40	1.312 33.33	.750 19.05	.156 4.0	206	265	45	SWA 4GUU
.875 22.23	1.125 28.58	1.437 36.50	.875 22.23	.156 4.0	225	314	62	SWA 6GUU
1.125 28.58	1.375 34.93	1.688 42.88	1.000 25.40	.156 4.0	510	784	130	SWA 8GUU
1.437 36.50	1.750 44.45	2.125 53.98	1.125 28.58	.188 4.8	774	1,180	240	SWA 10GUU
1.563 39.69	1.875 47.63	2.375 60.33	1.250 31.75	.188 4.8	862	1,370	290	SWA 12GUU
1.938 49.21	2.375 60.33	2.875 73.03	1.750 44.45	.219 5.6	980	1,570	615	SWA 16GUU
2.500 63.50	3.000 76.20	3.500 88.90	2.000 50.80	.219 5.6	1,570	2,740	1,300	SWA 20GUU
2.875 73.03	3.500 88.90	4.125 104.78	2.500 63.50	.281 7.2	2,160	4,020	1,900	SWA 24GUU
3.625 92.08	4.500 114.30	5.250 133.35	3.250 82.55	.406 10.5	3,820	7,940	3,600	SWA 32GUU

SI UNIT 1 N ≈ .225 lbs 1 kg ≈ 2.205 lbs

SWJ TYPE – CLEARANCE ADJUSTABLE BLOCK TYPE (INCH SERIES)

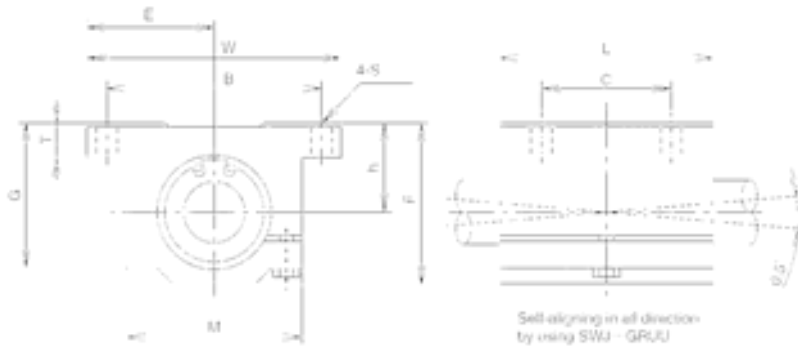

PART NUMBER	MAJOR DIMENSIONS						
	INNER CONTACT DIAMETER INCH/MM	OUTER DIMENSIONS					
		h ±.001/±.002 INCH/MM	E ±.001/±.002 INCH/MM	W INCH/MM	L INCH/MM	F INCH/MM	T INCH/MM
SWJ 8GUU	.5000 12.700	.6870 17.450	1.0000 25.400	2.000 50.80	1.688 42.86	1.250 31.75	.250 6.35
SWJ 10GUU	.6250 15.875	.8750 22.225	1.2500 31.750	2.500 63.50	1.938 49.21	1.625 41.28	.281 7.14
SWJ 12GUU	.7500 19.050	.9370 23.800	1.3750 34.925	2.750 69.85	2.063 52.39	1.750 44.45	.313 7.94
SWJ 16GUU	1.0000 25.400	1.1870 30.150	1.6250 41.275	3.250 82.55	2.813 71.44	2.188 55.56	.375 9.53
SWJ 20GUU	1.2500 31.750	1.5000 38.100	2.0000 50.800	4.000 101.60	3.625 92.08	2.813 71.44	.438 11.11
SWJ 24GUU	1.5000 38.100	1.7500 44.450	2.3750 60.325	4.750 120.65	4.000 101.60	3.250 82.55	.500 12.70
SWJ 32GUU	2.0000 50.800	2.1250 53.975	3.0000 76.200	6.000 152.40	5.000 127.00	4.063 103.19	.625 15.88

MAJOR DIMENSIONS					BASIC LOAD RATING		MASS g	PART NUMBER
OUTER DIMENSIONS		MOUNTING DIMENSIONS			DYNAMIC C N	STATIC Co N		
G INCH/MM	M INCH/MM	B ±.01/±.02 INCH/MM	C ±.01/±.02 INCH/MM	S INCH/MM				
1.125 28.58	1.375 34.93	1.688 42.88	1.000 25.40	.156 4.0	510	784	130	SWJ 8GUU
1.437 36.50	1.750 44.45	2.125 53.98	1.125 28.58	.188 4.8	774	1,180	240	SWJ 10GUU
1.563 39.69	1.875 47.63	2.375 60.33	1.250 31.75	.188 4.8	862	1,370	290	SWJ 12GUU
1.938 49.21	2.375 60.33	2.875 73.03	1.750 44.45	.219 5.6	980	1,570	615	SWJ 16GUU
2.500 63.50	3.000 76.20	3.500 88.90	2.000 50.80	.219 5.6	1,570	2,740	1,300	SWJ 20GUU
2.875 73.03	3.500 88.90	4.125 104.78	2.500 63.50	.281 7.2	2,160	4,020	1,900	SWJ 24GUU
3.625 92.08	4.500 114.30	6.000 152.40	3.250 82.55	.406 10.5	3,820	7,940	3,600	SWJ 32GUU

SI UNIT 1 N ≈ .225 lbs 1 kg ≈ 2.205 lbs

SWD TYPE – OPEN BLOCK TYPE (INCH SERIES)

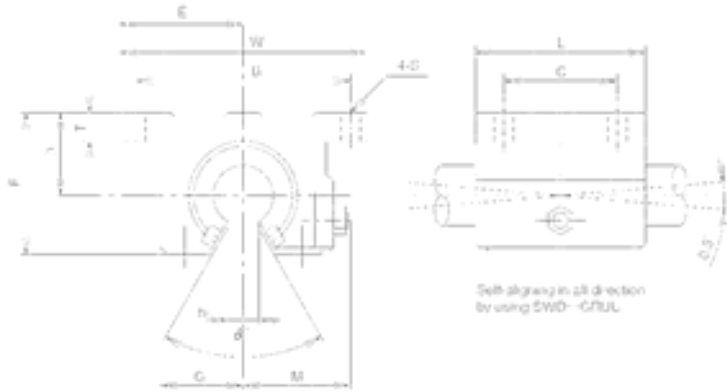

PART NUMBER	MAJOR DIMENSIONS							
	INNER CONTACT DIAMETER INCH/MM	OUTER DIMENSIONS						
		h ±.001/±.002 INCH/MM	E ±.001/±.002 INCH/MM	W INCH/MM	L INCH/MM	F INCH/MM	T INCH/MM	G INCH/MM
SWD 8GUU	.5000 12.700	.6870 17.450	1.0000 25.400	2.000 50.80	1.500 38.10	1.100 27.94	.250 6.35	.688 17.5
SWD 10GUU	.6250 15.875	.8750 22.225	1.2500 31.750	2.500 63.50	1.750 44.45	1.375 34.93	.281 7.14	.875 22.23
SWD 12GUU	.7500 19.050	.9370 23.800	1.3750 34.950	2.750 69.85	1.875 47.63	1.535 39.00	.315 8.00	.937 23.80
SWD 16GUU	1.0000 25.400	1.1870 30.150	1.6250 41.300	3.250 82.55	2.625 66.68	1.975 50.17	.375 9.53	1.188 30.18
SWD 20GUU	1.2500 31.750	1.5000 38.100	2.0000 50.800	4.000 101.60	3.375 85.73	2.485 63.12	.437 11.10	1.500 38.10
SWD 24GUU	1.5000 38.100	1.7500 44.450	2.3750 60.325	4.750 120.65	3.750 95.25	2.910 73.90	.500 12.70	1.750 44.45
SWD 32GUU	2.0000 50.800	2.1250 53.975	3.0000 76.200	6.000 152.40	4.750 120.65	3.660 92.90	.625 15.88	2.250 57.15

PART NUMBER	MAJOR DIMENSIONS						BASIC LOAD RATING		MASS g
	OUTER DIMENSIONS			MOUNTING DIMENSIONS			DYNAMIC C N	DYNAMIC Co N	
	M INCH/MM	h ₁ INCH/MM	θ	B ±.01/±.02 INCH/MM	C ±.01/±.02 INCH/MM	S INCH/MM			
SWD 8GUU	.98 24.89	.3425 8.70	80°	1.688 42.88	1.000 25.40	.156 4.0	510	784	98
SWD 10GUU	1.15 29.21	.375 9.53	80°	2.125 53.98	1.125 28.58	.188 4.8	774	1,180	185
SWD 12GUU	1.23 31.24	.4375 11.11	60°	2.375 60.33	1.250 31.75	.188 4.8	862	1,370	235
SWD 16GUU	1.48 37.59	.5625 14.29	50°	2.875 73.03	1.750 44.45	.218 5.6	980	1,570	530
SWD 20GUU	1.88 47.75	.625 15.88	50°	3.500 88.90	2.000 50.80	.218 5.6	1,570	2,740	1,080
SWD 24GUU	2.12 53.85	.750 19.05	50°	4.125 104.78	2.500 63.50	.281 7.4	2,160	4,020	1,620
SWD 32GUU	2.70 68.58	1.00 25.40	50°	5.250 133.35	3.250 82.55	.406 10.5	3,820	7,940	3,100

SI UNIT 1 N = .225 lbs 1 kg ≈ 2.205 lbs

SW TYPE – STANDARD TYPE



PART NUMBER	# OF BALL CIRCUITS	MAJOR DIMENSIONS INCH/MM								
		dr			D		L		B	
		INCH MM	tolerance inch / μ m		INCH MM	tolerance inch / μ m	INCH MM	tolerance inch / μ m	INCH MM	tolerance inch / μ m
SW 4	3	.2500 6.350	0 -0.00025	0 -0.00040	.5000 12.700	0/-0.00045 0/-11	.7500 19.050	0 -0.008	.5110 12.98	0 -0.008
SW 6	4	.3750 9.525	0 -0.00035	0 -0.00050	.6250 15.875	0 -0.00050	.8750 22.225	0 -0.012	.6358 16.15	0 -0.012
SW 8	4	.5000 12.700	0 -6	0 -9	.8750 22.225	0 -13	1.2500 31.750	0 -0.2	.9625 24.46	0 -0.2
SW 10	4	.625 15.875	0 -0.00030	0 -0.00040	1.1250 28.575	0 -0.00065	1.5000 38.100	0 -0.3	1.1039 28.04	0 -0.3
SW 12	5	.7500 19.050	0 -7	0 -10	1.2500 31.750	0 -0.00075	1.6250 41.275	0 -0.4	1.1657 29.61	0 -0.4
SW 16	6	1.0000 25.400	0 -0.00035	0 -0.00050	1.5625 39.688	0 -0.00090	2.2500 57.150	0 -0.5	1.7547 44.57	0 -0.5
SW 20	6	1.2500 31.750	0 -8	0 -12	2.0000 50.800	0 -0.00090	2.6250 66.675	0 -0.6	2.0047 50.92	0 -0.6
SW 24	6	1.5000 38.100	0 -9	0 -15	2.3750 60.325	0 -0.00100	3.0000 76.200	0 -0.7	2.4118 61.26	0 -0.7
SW 32	6	2.0000 50.800	0 -0.00040	0 -0.00060	3.0000 76.200	0 -0.00110	4.0000 101.600	0 -0.8	3.1917 81.07	0 -0.8
SW 40	6	2.5000 63.500	0 -0.00040	0 -0.00060	3.7500 95.250	0 -0.00120	5.0000 127.000	0 -0.9	3.9760 100.99	0 -0.9
SW 48	6	3.0000 76.200	0 -0.00040	0 -0.00060	4.5000 114.300	0 -0.00130	6.0000 152.400	0 -1.0	4.726 120.04	0 -1.0
SW 64	6	4.0000 101.600	0/-0.00040 0/-10	0/-0.00080 0/-20	6.0000 152.400	0/-0.00100 0/-25	8.0000 203.200	0 -0.4	6.258 158.95	0 -0.4

PART NUMBER	MAJOR DIMENSIONS INCH/MM		ECCENTRICITY		MAXIMUM RADIAL CLEARANCE inch / μ m	BASIC LOAD RATING		MASS g	SHAFT DIAMETER INCH / MM			
	W INCH / MM	D ₁ INCH / MM	PRECISION inch / μ m	HIGH inch / μ m		DYNAMIC C N	STATIC C ₀ N					
SW 4	.0390 0.992	.4687 11.906	.0003	.0005	-3	206	265	9.5	1/4 6.350			
SW 6	.0390 0.992	.5880 14.935				8	12	-4	225	314	15	3/8 9.525
SW 8	.0459 1.168	.8209 20.853				10	15	-6	510	784	42	1/2 12.700
SW 10	.0559 1.422	1.0590 26.899	.0004	.0006	-8	774	1,180	85	5/8 15.875			
SW 12	.0559 1.422	1.1760 29.870				12	20	-13	862	1,370	104	3/4 19.050
SW 16	.0679 1.727	1.4687 37.306	.0005	.0008	-10	980	1,570	220	1 25.400			
SW 20	.0679 1.727	1.8859 47.904				17	25	-13	1,570	2,740	465	1-1/4 31.750
SW 24	0.859 2.184	2.2389 56.870				17	25	-13	2,180	4,020	720	1-1/2 38.100
SW 32	.1029 2.616	2.8379 72.085	.0007	.0010	-13	3,820	7,940	1,310	2 50.800			
SW 40	.1200 3.048	3.5519 90.220				17	25	-13	4,700	10,000	2,600	2-1/2 63.500
SW 48	.1200 3.048	4.3100 109.474	.0008	.0012 30	-320	7,350	16,000	4,380	3 76.200			
SW 64	.1389 3.530	5.745 145.923				20	30	-320	14,100	34,800	10,200	4 101.600

1 N \approx .225 lbs 1 kg \approx 2.205 lbs

SW-AJ TYPE – CLEARANCE ADJUSTABLE TYPE

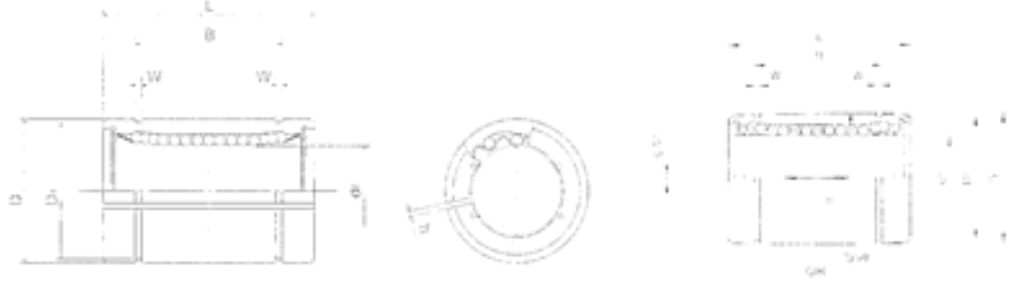

PART NUMBER	# OF BALL CIRCUITS	MAJOR DIMENSIONS INCH/MM							
		dr		D		L		B	
		INCH/MM	tolerance inch / μ m	INCH/MM	tolerance inch / μ m	INCH/MM	tolerance inch / μ m	INCH/MM	tolerance inch / μ m
SW 8-A-J	4	5.000 12.700	0 -0.00040	.8750 22.225	0 -0.00050	1.2500 31.750		.9625 24.46	
SW 10-A-J	4	.625 15.875	0 -9	1.1250 28.575	0 -13	1.5000 38.100	0 -0.2	1.1039 28.04	0 -0.2
SW 12-A-J	5	.7500 19.050	0 -0.00040	1.2500 31.750	0 -0.00065	1.6250 41.275		1.1657 29.61	
SW16-A-J	6	1.0000 25.400	0 -10	1.5625 39.688	0 -16	2.2500 57.150		1.7547 44.57	
SW 20-A-J	6	1.2500 31.750	0 -0.00050	2.0000 50.800	0 -0.00075	2.6250 66.675	0 -0.12	2.0047 50.92	0 -0.12
SW 24-A-J	6	1.5000 38.100	0 -12	2.3750 60.325	0 -19	3.0000 76.200	0	2.4118 61.26	0
SW 32-A-J	6	2.0000 50.800		3.0000 76.200	0 -0.00090	4.0000 101.600	0 -0.3	3.1917 81.07	0 -0.3
SW 40-A-J	6	2.5000 63.500	0 -0.00060	3.7500 95.250	0	5.0000 127.000		3.9760 100.99	
SW 48-A-J	6	3.0000 76.200	0 -15	4.50000 114.300	0 -22	6.0000 152.400	0 -0.16	4.726 120.04	0 -0.16
SW 64-A-J	6	4.0000 101.600	0/-0.00080 0/-20	6.0000 152.400	0/-0.00100 0/-25	8.0000 203.200	0 -0.4	6.258 158.95	0 -0.4

PART NUMBER	MAJOR DIMENSIONS INCH/MM			ECCENTRICITY inch / μ m	MAXIMUM RADIAL CLEARANCE inch / μ m	BASIC LOAD RATING		MASS g	SHAFT DIAMETER INCH / MM
	W INCH / MM	D ₁ INCH / MM	h INCH / MM			DYNAMIC C N	STATIC Co N		
SW 8-A-J	.0459 1.168	.8209 20.853	.06 1.5	.0005	-0.0001	510	748	41	1/2 12.700
SW 10-A-J	.0559 1.422	1.0590 26.899	.06 1.5	12	-4	774	1,180	83	5/8 15.875
SW 12-A-J	.0559 1.422	1.1760 29.870	.06 1.5	.0006	-0.0002	862	1,370	102	3/4 19.050
SW16-A-J	.0679 1.727	1.4687 37.306	.06 1.5	15	-6	980	1,570	218	1 25.400
SW 20-A-J	.0679 1.727	1.8859 47.904	.10 2.5	.0008	-0.0003	1,570	2,740	455	1-1/4 31.750
SW 24-A-J	0.859 2.184	2.2389 56.870	.12 3	20	-8	2,180	4,020	710	1-1/2 38.100
SW 32-A-J	.1029 2.616	2.8379 72.085	.12 3		-0.0005	3,820	7,940	1,290	2 50.800
SW 40-A-J	.1200 3.048	3.5519 90.220	.12 3	.0010	-13	4,700	10,000	2,560	2-1/2 63.500
SW 48-A-J	.1200 3.048	4.3100 109.474	.12 3	25	-0.0008	7,350	16,000	4,350	3 76.200
SW 64-A-J	.1389 3.530	5.745 145.923	.12 3	.0012 30	-20	14,100	34,800	10,150	4 101.60

1 N ≈ .225 lbs 1 kg ≈ 2.205 lbs

SW-OP TYPE – OPEN TYPE



PART NUMBER	# OF BALL CIRCUITS	MAJOR DIMENSIONS INCH/MM							
		dr		D		L		B	
		INCH/MM	tolerance inch / μ m	INCH/MM	tolerance inch / μ m	INCH/MM	tolerance inch / μ m	INCH/MM	tolerance inch / μ m
SW 8-OP	3	.5000 12.700	0 -0.00040	.8750 22.225	0 -0.00050	1.2500 31.750	0 -0.008 0 -0.2 0 -0.12 0 -0.3 0 -0.16 0 -0.4	.9625 24.46	0 -0.008
SW 10-OP	3	.625 15.875	0 -9	1.1250 28.575	0 -13	1.500 38.100		1.1039 28.04	0 -0.2
SW 12-OP	4	.7500 19.050	0 -0.00010	1.2500 31.750	0 -0.00065	1.6250 41.275		1.1657 29.61	0 -0.12
SW16-OP	5	1.0000 25.400	0 -10	1.5625 39.688	0 -16	2.2500 57.150		1.7547 44.57	0 -0.3
SW 20-OP	5	1.2500 31.750	0 -0.00050	2.0000 50.800	0 -0.00075	2.6250 66.675		2.0047 50.92	0 -0.16
SW 24-OP	5	1.5000 38.100	0 -12	2.3750 60.325	0 -19	3.0000 76.200		2.4118 61.26	0 -0.3
SW 32-OP	5	2.0000 50.800	0 -0.00060	3.0000 76.200	0 -0.00090	4.0000 101.600		3.1917 81.07	0 -0.16
SW 40-OP	5	2.5000 63.500	0 -0.00060	3.7500 95.250	0 -22	5.0000 127.000		3.9760 100.99	0 -0.4
SW 48-OP	5	3.0000 76.200	0 -15	4.50000 114.300	0 -25	6.0000 152.400		4.726 120.04	0 -0.4
SW 64-OP	5	4.0000 101.600	0/-0.00080 0/-20	6.0000 152.400	0/-0.00100 0/-25	8.0000 203.200		6.258 158.95	0 -0.4

PART NUMBER	MAJOR DIMENSIONS INCH/MM				ECCENTRICITY inch / μ m	MAXIMUM RADIAL CLEARANCE inch / μ m	BASIC LOAD RATING		MASS g	SHAFT DIAMETER INCH/MM
	W INCH/MM	D ₁ INCH/MM	h INCH/MM	θ			DYNAMIC C N	STATIC Co N		
SW 8-OP	.0459 1.168	.8209 20.853	.34 7.9375	80°	.0005 12	-0.001 -4	510	784	32	1/2 12.700
SW 10-OP	.0559 1.422	1.0590 26.899	.375 9.5250	80°			774	1,180	64	5/8 15.875
SW 12-OP	.0559 1.422	1.1760 29.870	.4375 11.1125	60°	.0006 15	-0.002 -6	862	1,370	86	3/4 19.050
SW16-OP	.0679 1.727	1.4687 37.306	.5625 14.2875	50°			980	1,570	190	1 25.400
SW 20-OP	.0679 1.727	1.8859 47.904	.625 15.875	50°	.0008 20	-0.003 -8	1,570	2,740	390	1-1/4 31.750
SW 24-OP	0.859 2.184	2.2389 56.870	.75 19.05	50°			2,180	4,020	610	1-1/2 38.100
SW 32-OP	.1029 2.616	2.8379 72.085	1.0 25.40	50°	.0010 25	-0.005 -13	3,820	7,940	1,120	2 50.800
SW 40-OP	.1200 3.048	3.5519 90.220	1.25 31.75	50°			4,700	10,000	2,230	2-1/2 63.500
SW 48-OP	.1200 3.048	4.3100 109.474	1.5 38.10	50°	.0012 30	-0.008 -20	7,350	16,000	3,750	3 76.200
SW 64-OP	.1389 3.530	5.745 145.923	2.0 50.8	50°			14,100	34,800	8,740	4 101.60

1 N ≈ .225 lbs 1 kg ≈ 2.205 lbs

SHAFT END SUPPORTS

INCH SHAFT END SUPPORTS – WH-A TYPE

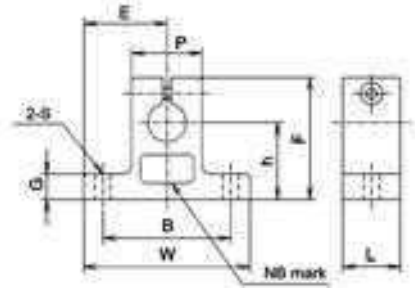

MAJOR DIMENSIONS INCH/MM												
PART NUMBER	SHAFT DIAMETER INCH/MM	h ± .001 ± 0.02	E ± .001 ± 0.02	W	L	F	G	P	B ± .01 ± 0.2	S	BOLT	MASS g
WH 4A	.2500 6.350	.6875 17.463	.7500 19.050	1.500 38.10	.500 12.70	1.063 27.00	.250 6.35	.500 12.70	1.125 28.58	.156 4.0	#6	15
WH 6A	.3750 9.525	.7500 19.050	.8125 20.637	1.625 41.28	.563 14.30	1.187 30.16	.250 6.35	.688 17.46	1.250 31.75	.156 4.0	#6	21
WH 8A	.5000 12.700	1.0000 25.400	1.0000 25.400	2.000 50.80	.625 15.88	1.625 41.28	.250 6.35	.875 22.23	1.500 38.10	.188 4.8	#8	35
WH 10A	.6250 15.875	1.0000 25.400	1.2500 31.750	2.500 63.50	.688 17.46	1.750 44.45	.313 7.94	1.000 25.40	1.875 47.63	.218 5.6	#10	52
WH 12A	.7500 19.050	1.2500 31.750	1.2500 31.750	2.500 63.50	.750 19.05	2.063 52.40	.313 7.94	1.250 31.75	2.000 50.80	.218 5.6	#10	74
WH 16A	1.0000 25.400	1.5000 38.100	1.5315 38.900	3.063 77.80	1.000 25.40	2.500 63.50	.375 9.53	1.500 38.10	2.500 63.50	.281 7.2	1/4	136
WH 20A	1.2500 31.750	1.7500 44.450	1.8750 47.625	3.750 95.25	1.125 28.58	3.000 76.20	.438 11.14	2.000 50.80	3.000 76.20	.346 8.8	5/16	254
WH 24A	1.5000 38.100	2.0000 50.800	2.1875 55.550	4.375 111.13	1.250 31.75	3.437 87.30	.500 12.70	2.250 57.15	3.500 88.90	.346 8.8	5/16	340
WH 32A	2.0000 50.800	2.5000 63.500	2.7500 69.850	5.500 139.70	1.500 38.10	4.375 111.13	.625 15.88	3.000 76.20	4.500 114.30	.406 10.5	3/8	670

METRIC SHAFT END SUPPORTS – SH-A TYPE



MAJOR DIMENSIONS INCH/MM												
PART NUMBER	SHAFT DIAMETER MM	h MM	E MM	W MM	L MM	F MM	G MM	6P MM	B MM	S (BOLT SIZE) MM	M ⁴ ADJUSTING BOLT SIZE	MASS g
SH 8A	8	20	21	42	14	32.8	6	18	32	5.5 (M5)	M 4	24
SH10A	10	20	21	42	14	32.8	6	18	32	5.5 (M5)	M 4	24
SH12A	12	23	21	42	14	37.5	6	20	32	5.5 (M5)	M 4	30
SH13A	13	23	21	42	14	37.5	6	20	32	5.5 (M5)	M 4	30
SH16A	16	27	24	48	16	44	8	25	38	5.5 (M5)	M 4	40
SH20A	20	31	30	60	20	51	10	30	45	6.6 (M6)	M 5	70
SH25A	25	35	35	70	24	60	12	38	56	6.6 (M6)	M 6	130
SH30A	30	42	42	84	28	70	12	44	64	9 (M8)	M 6	180
SH35A	35	50	49	98	32	82	15	50	74	11 (M10)	M 8	270
SH40A	40	60	57	114	36	96	15	60	90	11 (M10)	M 8	420
SH50A	50	70	63	126	40	120	18	74	100	14 (M12)	M 12	750
SH60A	60	80	74	148	45	136	18	90	120	14 (M12)	M 12	1,100



TECHNICO

Motion Control Products

www.technico.com

(330) 847-7000 PH

766 North River Rd. N.W.
Warren, OH 44483

Steven J. Lussier
President

PH: (330) 847-7000
Cell (330) 219-3853

E-Mail: slussier@technico.com

Robert J. O'Leary

Sales Engineer
Pennsylvania Office
PH: (412) 487-8631
Cell (412) 612-0467

E-Mail: roleary@technico.com

Adam Phillips

Territory Sales Manager
Ohio Office

PH (330) 847-7000
Cell (330) 219-0582

E-Mail: aphillips@technico.com



Technico, Inc. is an established Sales and Distribution Organization, offering factory automation and motion control products and services required for industrial automation applications. Our company offers a complete sales and support staff to assist customers with all of their factory automation and motion control needs. Our primary sales efforts target mechanical and electrical design engineers, as well as purchasing and maintenance personnel.

Incorporated in 1986, our staff consists of Outside Sales, Engineering and Administrative Services, Inside Sales and Machining specialists. Technico also has warehouse and machine shop that provide inventory, shipping, receiving, assembly and machining services on site. Technico owns and occupies a 10,000 sq. ft. building, 8,000 of which is warehouse and machine shop space.

We specialize in offering a broad range of factory automation and motion control products to OEMs in a wide variety of industries. Primary industrial applications include machine tool, metalworking, automotive, automation, transfer equipment, glass, robotics, tire and rubber, medical, injection molding, pick and place, press, steel mill equipment, packaging, and special machinery, among others.

We also have an established presence with large and small end user accounts, including automotive assembly plants, steel mills, stamping facilities, light and lamp plants, and a host of other factory automation industrial users.

Please feel free to contact a member of our sales staff with any questions or comments or to learn more about the motion control products we supply.

We look forward to doing business with you!

TECHNICO

766 North River Rd. Warren, OH 44483 www.technico.com

Authorized Distributor



THK offers the world's most complete line of Linear Motion Systems and products for your Motion Control and Automation needs. These systems include Linear Motion Slides, Ball Screws, Ball Splines, Linear Actuators and Stages, as well as other linear motion products.



Thomson Industries manufactures the broadest standard product offerings including Industrial Ball Screws, Ball Screw End Supports, Linear Guides and Components, Linear Systems, Positioning Slides, Industrial and Precision Linear Actuators, Lead Screws, Gearheads, Brakes & Clutches, Precision Balls and Linear Slides



eShaft Case 60 is engineered round linear shafting, manufactured to extremely close industry tolerances on diameter, straightness, and roundness. Designed for use in all Motion Control applications and engineered to exacting standards.



Technico Design and Machine includes Machining Services, Application Engineering, and custom Mechanical and Electro-Mechanical Motion Control solutions to support our customers in the Motion Control and Automation Industries.



Nanotec Electronic supplies drive solutions based on high performance stepper motors, BLDC motors, linear actuators, and innovative motor controllers. Years of experience are reflected in high performance, energy-saving solutions including the Plug & Drive motors, integrated motor controllers, and other products for your motion control prices



AirTAC specializes in producing Pneumatic Products - Cylinders and Valves. Fittings, Control Components, Preparation Units, Actuators and Linear Guides. With over 8500 employees and close to a billion dollars in sales, AirTAC is a leader in the industry.



R+W Coupling Technology manufactures couplings for the Power Transmission and Motion Control Industries. Coupling products include Metal Bellows, Safety, Miniature, Economy, Line Shaft, Elastomer, and Linear. Most products are available quickly.



ROLLON is a leading manufacturer of linear motion systems, guides and linear actuators that are designed to meet the requirements of engineers involved in machine design applications in the primary fields of industrial automation and robotics.

Nabell USA Corporation is a manufacturer of bellows and protective covers for a variety of applications, including medical equipment, machine tools (ball screw, linear way, linear guide, telescopic waycover, laser, water jet), precision instruments, camera & optical, clean room applications, and materials handling.



Zimmer clamping and braking elements routinely perform critical positioning, holding and braking tasks. They ensure precision during cutting processes and boost efficiency with short cycle times. Their secure hold maximizes safety and protects the machines.